

# AS

## TYPE



**T**ype AS is a roller type freewheel non-bearing supported. Bearings are required to support axial and radial loads. Lubrication and sealing must also be provided by the installation. Nominal outside dimensions are the same as series 62.. ball bearings.

A typical arrangement is to install this type alongside a series 62 bearing within the same location tolerances, as shown on the following page.

The inner race is keyed to the shaft (except 6 mm bore). The outer race has a positive  $r_6$  tolerance to give a press fit in a H7 housing. The outer housing must be strong enough to not expand after assembly. This design can accept an axial misalignment of inner and outer race of  $\pm S/2$ .

AS

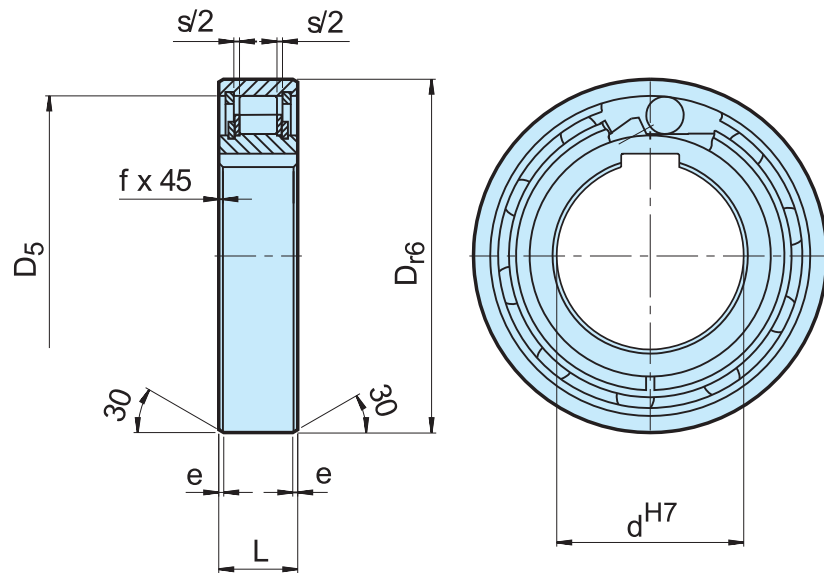

Type	Size	Overrunning speeds									Weight (kg)	Drag torque $T_R$ (Ncm)
		$T_{KN}^{1)}$ (Nm)	$n_{1max}^{2)}$ (min <sup>-1</sup> )	$n_{amax}^{3)}$ (min <sup>-1</sup> )	$D_{r6}$ (mm)	$D_5$ (mm)	L (mm)	s (mm)	e (mm)	f (mm)		
AS (NSS)	6	2,10	5000	7500	19	15,8	6	0,3	0,6	0,3	0,01	0,18
	8	3,8	4300	6500	24	20	8	1,3	0,6	0,6	0,02	0,24
	10	6,8	3500	5200	30	25,9	9	1,3	0,6	0,6	0,03	0,36
	12	13	3200	4800	32	28	10	1,3	0,6	0,6	0,04	0,48
	15	14	2800	4300	35	31	11	1,4	0,6	0,6	0,05	0,70
	20	40	2200	3300	47	40	14	2,4	0,8	0,8	0,12	1,4
	25	56	1900	2900	52	45,9	15	2,4	0,8	0,8	0,14	2,4
	30	90	1600	2400	62	55	16	2,4	0,8	1	0,22	7,8
	35	143	1300	2000	72	64	17	2,5	0,8	1	0,31	9,0
	40	185	1200	1800	80	72	18	2,5	0,8	1	0,39	10
	45	218	1000	1600	85	77	19	2,5	1,2	1	0,44	11
	50	230	950	1500	90	82	20	2,5	1,2	1	0,49	13
	55	308	800	1300	100	90	21	2,5	1,2	1	0,66	14
	60	508	700	1100	110	100	22	2,5	1,2	1,5	0,81	26
	80	1063	600	900	140	128	26	2,5	1,2	1,5	1,41	58

### NOTES

AS6 without keyway.  $\varnothing D = \begin{smallmatrix} -0 \\ -0,009 \end{smallmatrix}$   
 AS8-12 keyway to DIN 6885.1.  
 Other sizes to DIN 6885.3

1)  $T_{max} = 2 \times T_{KN}$   
 » Refer to Selection page 10 to 13

2) Inner race overruns

3) Outer race overruns

Mounting dimensions are identical to ball bearings series 62.  
 » Refer to mounting and maintenance instructions  
 page 16 to 19

### MOUNTING EXAMPLE

