

Complete Freewheels BM

for keyway connection on the outer ring
with rollers or with sprag lift-off X

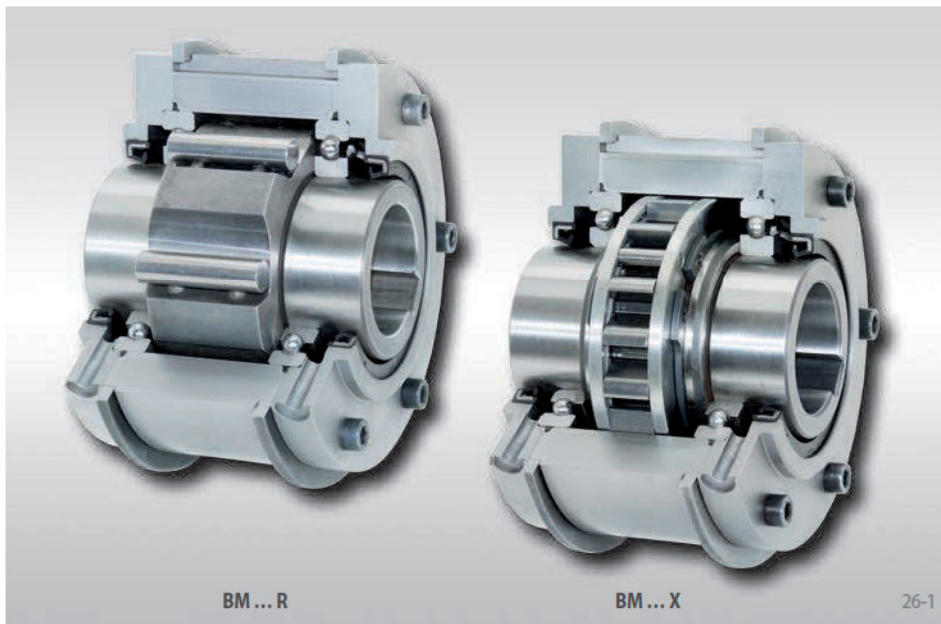

Application as

- ▶ Backstop
- ▶ Overrunning Clutch
- ▶ Indexing Freewheel

Features

Complete Freewheels BM are sealed freewheels with ball bearings. They are supplied oil-filled and ready for installation.

Besides the standard type, the type with sprag lift-off X is available for wearfree freewheeling operation at high speed rotating inner ring.

Nominal torques up to 57 500 Nm.

Bores up to 150 mm. A multitude of standardized bore diameters are available with short delivery times.

Application example

Complete Freewheel BM 60 SX as a backstop, arranged at the end of the intermediate shaft of a spur gearbox. The freewheel is used without the radial seal rings on each side, and is lubricated by the gearbox oil. A radial holding pin engages in the keyway of the outer ring. The backdriving torque is supported by the holding pin in the stationary housing. By removing the radial holding pin, the installation can be turned in both directions in order to carry out maintenance work. With the high shaft speed in normal operation (freewheeling operation), the type with sprag lift-off X is used; the sprags work in freewheeling operation without contact and hence are wear-free.

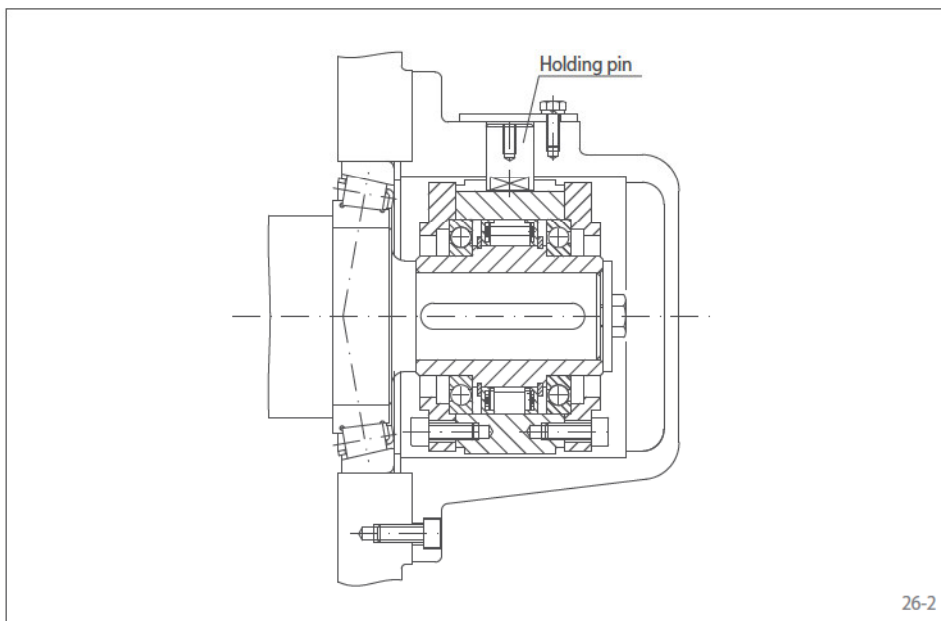

Complete Freewheels BM

for keyway connection on the outer ring
with rollers or with sprag lift-off X

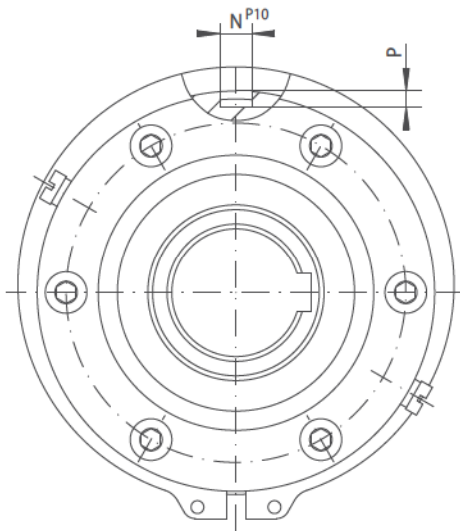

27-1

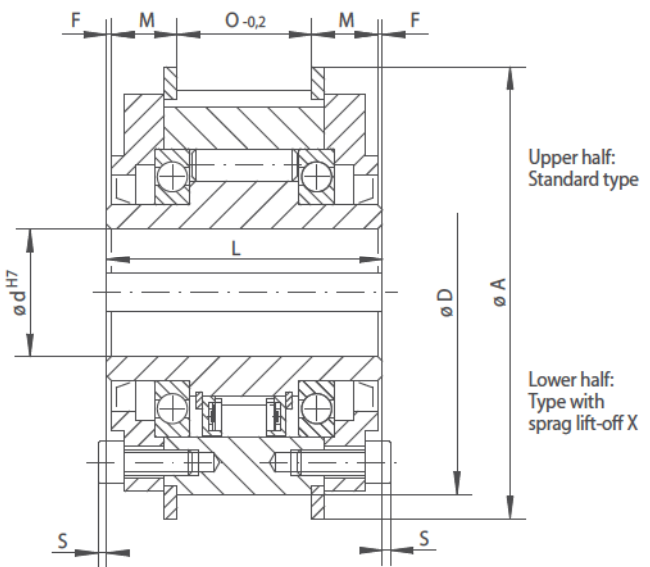

27-2

Indicing Freewheel Overrunning Clutch Backstop	Standard type For universal use	Type with sprag lift-off X For extended service life using sprags lift-off at high speed rotating inner ring	Dimensions

Freewheel Size	Type	Nominal torque M_N Nm	Max. speed		Type	Nominal torque M_N Nm	Sprag lift-off at inner ring speed min^{-1}	Max. speed		Bore d		A mm	D mm	F mm	L mm	M mm	N mm	O mm	P mm	S mm	Weight kg
			Inner ring freewheels/ overruns min^{-1}	Outer ring freewheels/ overruns min^{-1}				Inner ring freewheels/ overruns min^{-1}	Outer ring drives min^{-1}	Standard mm	max. mm										
BM 12	R	150	1 750	3 500						15	15	84	70	0,75	68	15,75	5	35	3,0	3,0	1,5
BM 15	R	230	1 650	3 300						20	20	94	80	0,75	70	15,75	5	37	3,0	3,0	2,0
BM 18	R	340	1 550	3 100						25	25	111	95	0,75	70	16,25	8	36	4,0	3,0	2,9
BM 20	R	420	1 450	2 900	DX	420	750	1 700	300	30	30	121	105	0,75	77	20,25	8	35	4,0	2,5	3,8
BM 25	R	800	1 250	2 500	DX	700	700	1 600	280	40	40	144	125	0,75	93	22,25	10	47	5,0	2,5	6,6
BM 28	R	1 200	1 100	2 200						45	45	155	135	0,75	95	23,25	12	47	5,0	4,0	7,8
BM 30	R	1 600	1 000	2 000	DX	1 250	630	1 600	252	50	50	171	150	0,75	102	24,25	12	52	5,0	4,0	10,3
BM 35	R	1 800	900	1 800						55	55	182	160	0,75	110	24,25	14	60	5,5	4,0	12,5
BM 40	R	3 500	800	1 600	SX	1 900	430	1 500	172	60	60	202	180	0,75	116	25,25	16	64	6,0	6,5	17,4
BM 45	R	7 100	700	1 500	SX	2 300	400	1 500	160	70	70	218	195	1,25	130	24,75	20	78	7,5	8,5	22,4
BM 50	R	7 500	700	1 400						75	75	227	205	1,25	132	26,75	20	76	7,5	8,5	24,2
BM 52	R	9 300	650	1 300	SX	5 600	320	1 500	128	80	80	237	215	1,75	150	33,75	25	79	9,0	8,5	31,1
BM 55	R	12 500	550	1 100	SX	7 700	320	1 250	128	90	90	267	245	1,75	170	35,25	25	96	9,0	6,5	45,6
BM 60	R	14 500	500	1 000	SX	14 500	250	1 100	100	100	105	314	290	1,75	206	40,25	28	122	10,0	6,5	78,2
BM 70	R	22 500	425	850	SX	21 000	240	1 000	96	120	120	350	320	1,25	215	44,75	28	123	10,0	9,0	93,4
BM 80	R	25 000	375	750						130	130	380	350	1,75	224	46,25	32	128	11,0	8,5	116,8
BM 90	R	33 500	350	700						140	140	400	370	2,75	236	49,25	32	132	11,0	7,5	136,7
BM 95	R	35 000	300	600						150	150	420	390	2,75	249	53,25	36	137	12,0	6,5	159,3
BM 100	R	57 500	250	500	UX	42 500	210	750	84	150	150	450	410	3,75	276	56,25	36	156	12,0	11,5	198,4

The maximum transmissible torque is 2 times the specified nominal torque. See page 14 for determination of selection torque.
Keyway according to DIN 6885, page 1 • Tolerance of keyway width JS10.

Mounting

The customer attachment part is connected via a keyway connection with the outer ring. The customer must provide the key required for assembling the attachment part.

The tolerance of the shaft must be ISO h6 or j6 and the tolerance of the pilot diameter D of the attachment part must be ISO H7 or J7.

Example for ordering

Freewheel size BM 20, standard type and 30 mm bore:

- BM 20 R, d = 30 mm