

Basic Freewheels FGR ... R

for assembly with connecting parts
with rollers

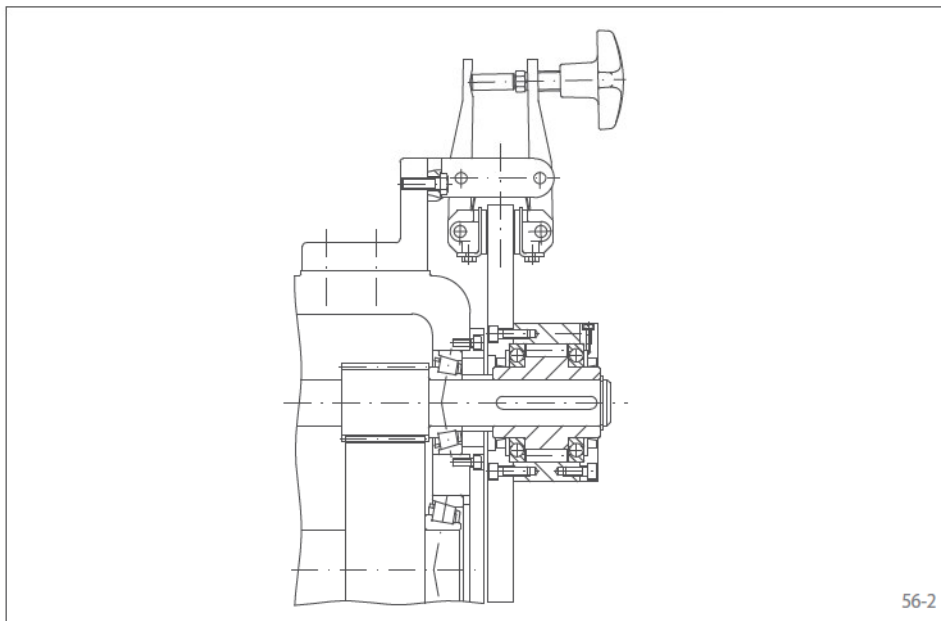

56-1



56-2

Application as

- ▶ Backstop
- ▶ Overrunning Clutch
- ▶ Indexing Freewheel

Features

Basic Freewheels FGR ... R are roller freewheels with ball bearings to be assembled with customer connecting parts. The freewheels are particularly suitable for installation in housings with oil lubrication and seals.

Nominal torques up to 68 000 Nm.

Bores up to 150 mm.

Application example

Basic Freewheel FGR 25 R as a backstop on a reduction gear in the drive of an inclined conveyor of an assembly train. When the unit stops, the conveyor belt must be held securely so that it does not run backwards by the weight of the assembly parts. A brake disk is fitted to the outer ring of the freewheel alongside a manually operated RINGSPANN brake calliper. The back-driving torque is maintained by the freewheel and the closed brake. During set-up it must be possible to move the installation in both directions of rotation. To do this, the brake calliper is opened manually.

for assembly with connecting parts
with rollers

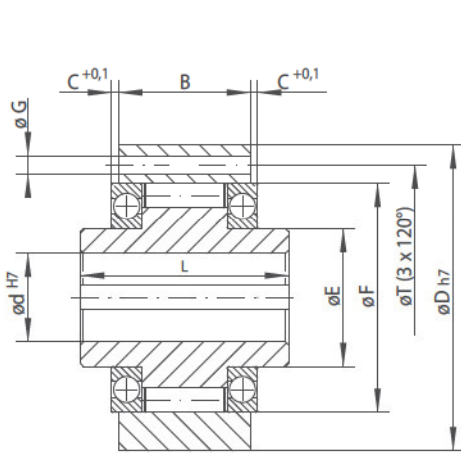

Size FGR 12

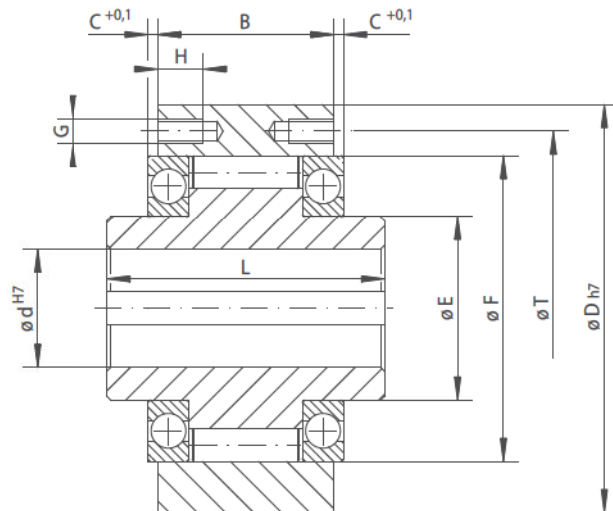

57-1 Size FGR 15 to FGR 150

57-2

Indicing Freewheel Overrunning Clutch Backstop	Standard type For universal use	Dimensions

Freewheel Size	Type	Nominal torque M_N Nm	Max. speed		Bore d mm	B mm	C mm	D mm	E mm	F mm	G**	H mm	L mm	T mm	Z**	Weight kg
			Inner ring freewheels/ overruns min^{-1}	Outer ring freewheels/ overruns min^{-1}												
FGR 12	R	55	2500	5400	12	20	3,5	62	20	42	5,5 mm	-	42	51	3	0,5
FGR 15	R	130	2200	4800	15	28	2,0	68	25	47	M 5	8	52	56	3	0,8
FGR 20	R	180	1900	4100	20	34	2,4	75	30	55	M 5	8	57	64	4	1,0
FGR 25	R	290	1550	3350	25	35	2,4	90	40	68	M 6	10	60	78	4	1,5
FGR 30	R	500	1400	3050	30	43	2,4	100	45	75	M 6	10	68	87	6	2,2
FGR 35	R	730	1300	2850	35	45	2,9	110	50	80	M 6	12	74	96	6	3,0
FGR 40	R	1 000	1 150	2 500	40	53	2,9	125	55	90	M 8	14	86	108	6	4,6
FGR 45	R	1 150	1 100	2 400	45	53	2,9	130	60	95	M 8	14	86	112	8	4,7
FGR 50	R	2 100	950	2 050	50	64	3,9	150	70	110	M 8	14	94	132	8	7,2
FGR 55	R	2 600	900	1 900	55	66	2,9	160	75	115	M 10	16	104	138	8	8,6
FGR 60	R	3 500	800	1 800	60	78	5,4	170	80	125	M 10	16	114	150	10	10,5
FGR 70	R	6 000	700	1 600	70	95	6,4	190	90	140	M 10	16	134	165	10	13,4
FGR 80	R	6 800	600	1 400	80	100	3,9	210	105	160	M 10	16	144	185	10	18,2
FGR 90	R	11 000	500	1 300	90	115	4,9	230	120	180	M 12	20	158	206	10	28,0
FGR 100	R	20 000	350	1 000	100	120	5,4	270	140	210	M 16	24	182	240	10	43,0
FGR 130	R	31 000	250	900	130	152	7,9	310	160	240	M 16	24	212	278	12	66,0
FGR 150	R	68 000	200	700	150	180	6,9	400	200	310	M 20	32	246	360	12	136,0

The maximum transmissible torque is 2 times the specified nominal torque. See page 14 for determination of selection torque.

Keyway according to DIN 6885, page 1 • Tolerance of keyway width JS10.

** Z = Number of tapped holes or mounting holes G on pitch circle T.

Mounting

The customer connecting parts are centered on the ball bearing external diameter F and assembled via the outer ring.

The tolerance of the shaft must be ISO h6 or j6 and the tolerance of the pilot diameter F of the connecting part must be ISO H7 or J7. The centering depth C must be observed.

Lubrication

An oil lubrication of the specified quality must be provided. Two flat seals are supplied for sealing between the faces of the outer ring and the connecting parts.

Example for ordering

Freewheel size FGR 35, standard type:

- FGR 35 R