

Complete Freewheels FGR ... R A1A2

with mounting flange
with rollers



Application as

- ▶ Backstop
- ▶ Overrunning Clutch
- ▶ Indexing Freewheel

Features

Complete Freewheels FGR ... R A1A2 with mounting flange are sealed roller freewheels with ball bearings. They are oil lubricated.

Nominal torques up to 68 000 Nm.

Bores up to 150 mm.

Application example

Complete Freewheel FGR 50 R A1A2, used in a hydraulically released, spring actuated multi-disk brake for winch drives. When the load is lifted, the multiple-disk brake is closed and the inner ring is freewheeling. At a standstill, the freewheel functions as a backstop. The load is held by the brake and the locked freewheel. When lowering, the brake is released with control and the load is lowered via the locked freewheel. By using the freewheel, the hydraulic control could be designed in a simpler and more cost-effective manner.

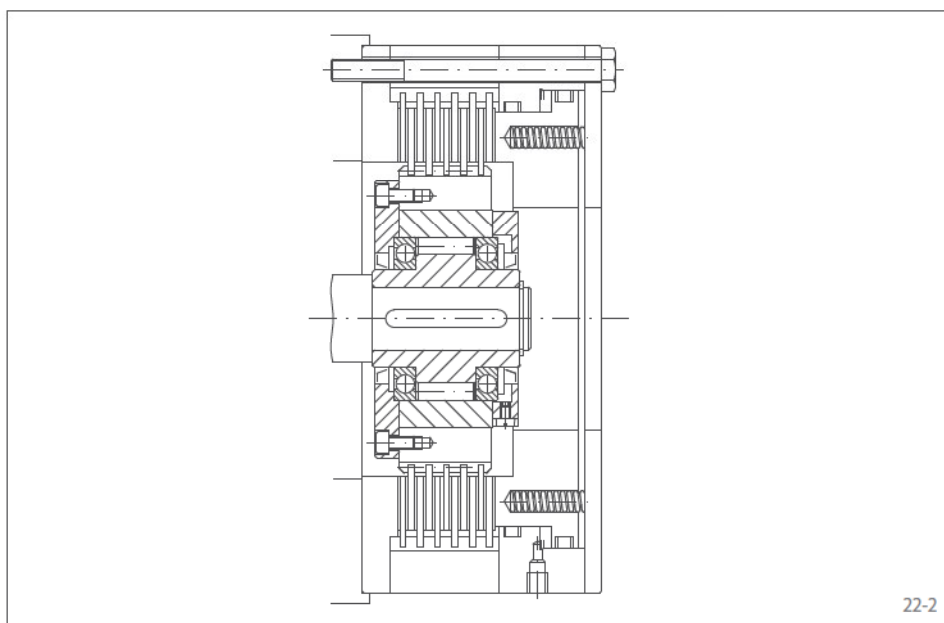

with mounting flange
with rollers

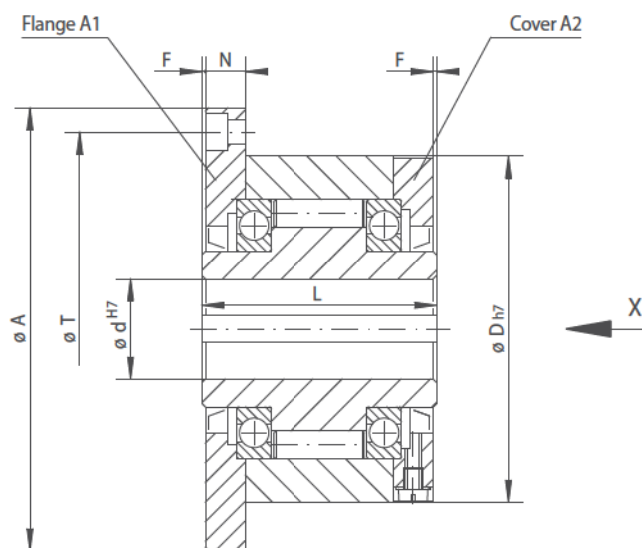

23-1

Indicing Freewheel Overrunning Clutch Backstop	Standard type For universal use	Dimensions

Freewheel Size	Type	Flange and cover combination	Nominal torque M_N Nm	Max. speed Inner ring freewheels/ overruns min^{-1}	Max. speed Outer ring freewheels/ overruns min^{-1}	Bore d mm	A mm	D mm	F mm	G* mm	L mm	N mm	T mm	Z* mm	Weight kg
FGR 12	R	A1A2	55	2 500	5 400	12	85	62	1	M 5	42	10,0	72	3	1,2
FGR 15	R	A1A2	130	2 200	4 800	15	92	68	1	M 5	52	11,0	78	3	1,6
FGR 20	R	A1A2	180	1 900	4 100	20	98	75	1	M 5	57	10,5	85	4	1,9
FGR 25	R	A1A2	290	1 550	3 350	25	118	90	1	M 6	60	11,5	104	4	2,9
FGR 30	R	A1A2	500	1 400	3 050	30	128	100	1	M 6	68	11,5	114	6	3,9
FGR 35	R	A1A2	730	1 300	2 850	35	140	110	1	M 6	74	13,5	124	6	4,9
FGR 40	R	A1A2	1 000	1 150	2 500	40	160	125	1	M 8	86	15,5	142	6	7,5
FGR 45	R	A1A2	1 150	1 100	2 400	45	165	130	1	M 8	86	15,5	146	8	7,8
FGR 50	R	A1A2	2 100	950	2 050	50	185	150	1	M 8	94	14,0	166	8	10,8
FGR 55	R	A1A2	2 600	900	1 900	55	204	160	1	M 10	104	18,0	182	8	14,0
FGR 60	R	A1A2	3 500	800	1 800	60	214	170	1	M 10	114	17,0	192	10	16,8
FGR 70	R	A1A2	6 000	700	1 600	70	234	190	1	M 10	134	18,5	212	10	20,8
FGR 80	R	A1A2	6 800	600	1 400	80	254	210	1	M 10	144	21,0	232	10	27,0
FGR 90	R	A1A2	11 000	500	1 300	90	278	230	1	M 12	158	20,5	254	10	40,0
FGR 100	R	A1A2	20 000	350	1 100	100	335	270	1	M 16	182	30,0	305	10	67,0
FGR 130	R	A1A2	31 000	250	900	130	380	310	1	M 16	212	29,0	345	12	94,0
FGR 150	R	A1A2	68 000	200	700	150	485	400	1	M 20	246	32,0	445	12	187,0

The maximum transmissible torque is 2 times the specified nominal torque. See page 14 for determination of selection torque.

Keyway according to DIN 6885, page 1 • Tolerance of keyway width JS10.

* Z = Number of fastening holes for screws G (DIN EN ISO 4762) on pitch circle T.

Mounting

Basic Freewheel, flange, cover, seals and screws are supplied loose. These must be assembled by the customer with regard to the required freewheeling direction into the Complete Freewheel. Prior to commissioning, the freewheel must be filled with oil of the specified quality. Upon request, assembled Complete Freewheels already oil-filled can be supplied.

The customer attachment part is centered on the external diameter D and bolted on via flange A1.

The tolerance of the shaft must be ISO h6 or j6 and the tolerance of the pilot diameter D of the attachment part must be ISO H7 or J7.

Example for ordering

Freewheel size FGR 25, standard type with flange A1 and cover A2:

- FGR 25 R A1A2

Basic Freewheel, flange, cover, seals and screws are supplied loose provided nothing else is stated in the order. If assembled, oil-filled, Complete Freewheels are to be supplied, this must be specified in the order. When ordering, please also specify the freewheeling direction of the inner ring when viewed in direction X:

- counterclockwise free or
- clockwise free