

# Complete Freewheels FGRN ... R A5A6

for keyway connection on the outer ring  
with rollers



## Application as

- ▶ Backstop
- ▶ Overrunning Clutch
- ▶ Indexing Freewheel

## Features

Complete Freewheels FGRN ... R A5A6 are sealed roller freewheels with ball bearings. They are oil lubricated.

Nominal torques up to 6 800 Nm.

Bores up to 80 mm.

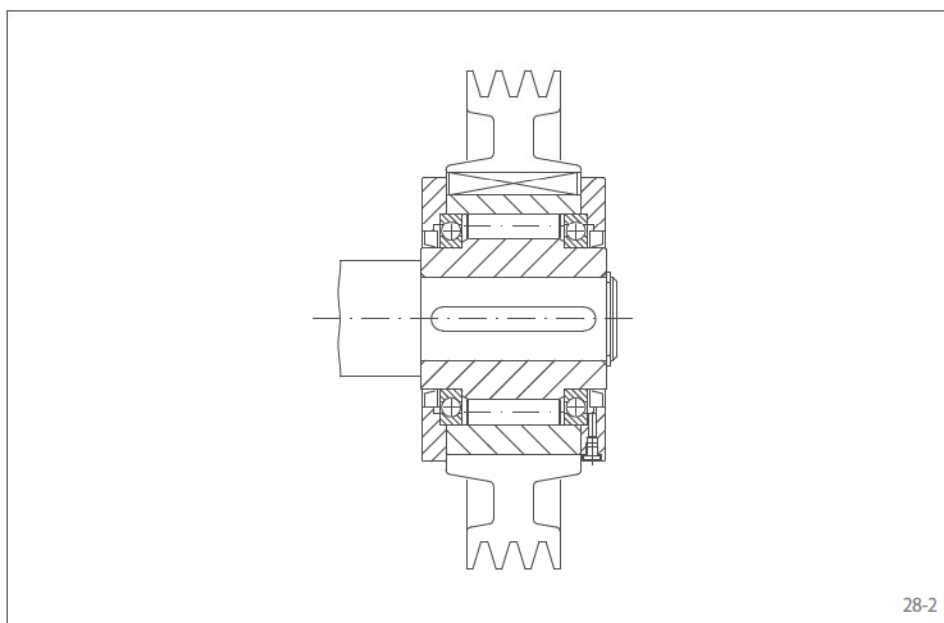

## Application example

Complete Freewheel FGRN 45 R as an overrunning clutch on the shaft end of a mobile fan. In normal operation, the fan is driven by a diesel motor via the V-belt drive. By doing so, the freewheel works in driving operation. When the motor is turned off, the freewheel automatically disengages the rotating flywheel mass of the fan from the drive. In this operating state, the inner ring overruns the stationary outer ring; the freewheel works in freewheeling operation.

for keyway connection on the outer ring  
with rollers

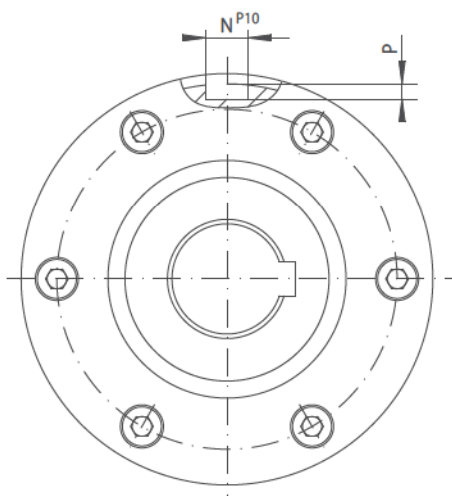

29-1

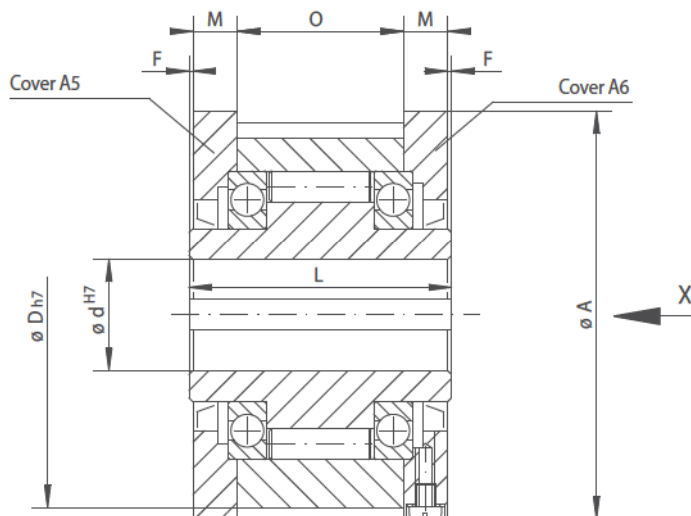

29-2

Indoing Freewheel Overrunning Clutch Backstop	Standard type For universal use	Dimensions

Freewheel Size	Type	Cover combination	Nominal Torque $M_N$ Nm	Max. speed		Bore $d$ mm	A mm	D mm	F mm	L mm	M mm	N mm	P mm	O mm	Weight kg
				Inner ring freewheels/overruns $\text{min}^{-1}$	Outer ring freewheels/overruns $\text{min}^{-1}$										
FGRN 12	R	A5A6	55	2 500	5 400	12	70	62	1	42	10,0	4	2,5	20	1,2
FGRN 15	R	A5A6	130	2 200	4 800	15	76	68	1	52	11,0	5	3,0	28	1,6
FGRN 20	R	A5A6	180	1 900	4 100	20	84	75	1	57	10,5	6	3,5	34	1,9
FGRN 25	R	A5A6	290	1 550	3 350	25	99	90	1	60	11,5	8	4,0	35	2,9
FGRN 30	R	A5A6	500	1 400	3 050	30	109	100	1	68	11,5	8	4,0	43	3,9
FGRN 35	R	A5A6	730	1 300	2 850	35	119	110	1	74	13,5	10	5,0	45	4,9
FGRN 40	R	A5A6	1 000	1 150	2 500	40	135	125	1	86	15,5	12	5,0	53	7,5
FGRN 45	R	A5A6	1 150	1 100	2 400	45	140	130	1	86	15,5	14	5,5	53	7,8
FGRN 50	R	A5A6	2 100	950	2 050	50	160	150	1	94	14,0	14	5,5	64	10,8
FGRN 55	R	A5A6	2 600	900	1 900	55	170	160	1	104	18,0	16	6,0	66	14,0
FGRN 60	R	A5A6	3 500	800	1 800	60	182	170	1	114	17,0	18	7,0	78	16,8
FGRN 70	R	A5A6	6 000	700	1 600	70	202	190	1	134	18,5	20	7,5	95	20,8
FGRN 80	R	A5A6	6 800	600	1 400	80	222	210	1	144	21,0	22	9,0	100	27,0

The maximum transmissible torque is 2 times the specified nominal torque. See page 14 for determination of selection torque.  
Keyway according to DIN 6885, page 1 • Tolerance of keyway width JS10.

## Mounting

Basic Freewheel, covers, seals and screws are supplied loose. These must be assembled by the customer with regard to the required freewheeling direction into the Complete Freewheel. Prior to commissioning, the freewheel must be filled with oil of the specified quality. Upon request, assembled Complete Freewheels already oil-filled can be supplied.

The customer attachment part is connected via a keyway connection with the outer ring. The customer must provide the key required for assembling the attachment part.

The tolerance of the shaft must be ISO h6 or j6 and the tolerance of the pilot diameter D of the attachment part must be ISO H7 or J7.

## Example for ordering

Freewheel size FGRN 60, standard type with flange A5 and cover A6:

- FGRN 60 R A5A6

Basic Freewheel, covers, seals and screws are supplied loose provided nothing else is stated in the order.

If assembled, oil-filled, Complete Freewheels are to be supplied, this must be specified in the order. When ordering, please also specify the freewheeling direction of the inner ring when viewed in direction X:

- counterclockwise free or
- clockwise free