

Complete Freewheel Clutch Unit FN

with keyway (IR)



Characteristics

Width
27 mm

Operating temperature
max. 140°C
Higher temperatures on request

Lubrication

oil or grease lubrication (Pg. 60–61)
Delivered with corrosion protection.
Operative grease filling on request.

Installation

Installation tolerances
Shaft js6 (k5); hub H6

Mating parts

Hardening and grinding of the mating parts is not necessary. Thoroughly clean (grease free) the mating parts in the vicinity of the freewheel clutch as well as the freewheel clutch's rings before making the press fit.

Bearing

The freewheel clutch includes ball and roller bearings. Additional external bearing support is not necessary.

Press fit pressure

Press fit pressure must not be applied to the balls.

Clamping direction

The arrow on the inner ring designates the inner ring's clamping direction.

Components

Freewheel clutch insert element* FE 400 M (meander spring)
FE 400 Z (tension spring)

+ Raceways Bearing steel, hardened and ground
inner ring Keyway per DIN 6885, Sheet 1
Tolerance: P9 with back clearance
outer ring Press fit

+ Ball bearing Integrated

+ Roller bearing RL 400

- Lubrication -

- Seal -

* available with either freewheel clutch insert element FE 400 M (meander spring) or FE 400 Z (tension spring).

Data

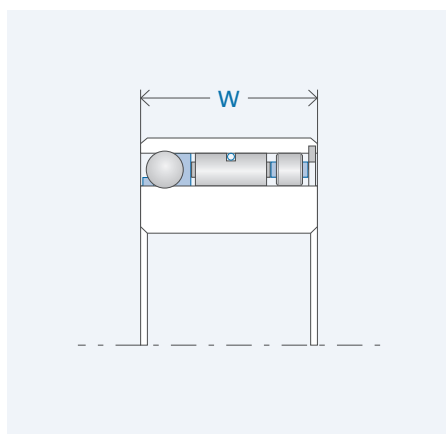
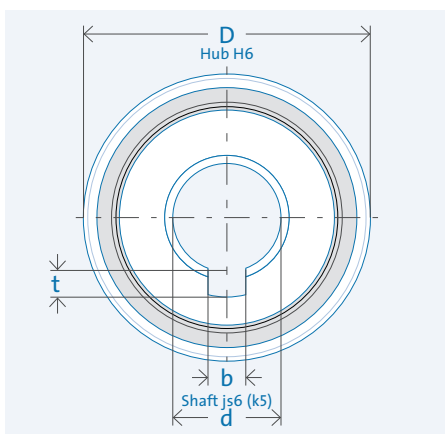

Drawing legend

- d = inner diameter
- D = outer diameter
- W = width
- T = torque
- n = rotation speed
- C = load capacity
- b = keyway width
- t = keyway depth

Designation	d [mm]	D [mm]	W [mm]	T _{nom} [Nm]	n _{max} [rpm]	C _{dyn.} [N]	C _{stat.} [N]	Weight [kg]	b [mm]	t [mm]	Item no.
FN 437 M	15	41	27	176	4,800	8,962	8,661	0.19	15	2.3	300706
FN 437 Z	15	41	27	160	4,800	8,962	8,661	0.19	15	2.3	300707
FN 442 M	20	46	27	223	4,200	10,247	10,708	0.22	20	2.8	300712
FN 442 Z	20	46	27	208	4,200	10,247	10,708	0.22	20	2.8	300714
FN 453 M	25	58	27	343	3,400	11,417	13,577	0.36	25	3.3	300718
FN 453 Z	25	58	27	314	3,400	11,417	13,577	0.36	25	3.3	300719
FN 459 M	30	64	27	411	3,000	12,691	16,320	0.43	30	3.3	300726
FN 459 Z	30	64	27	381	3,000	12,691	16,320	0.43	30	3.3	300728
FN 463 M	35	68	27	461	2,900	13,070	17,063	0.47	35	3.3	306526
FN 463 Z	35	68	27	427	2,900	13,070	17,063	0.47	35	3.3	306527
FN 470 M	40	75	27	550	2,600	14,050	19,840	0.54	40	3.3	300731
FN 470 Z	40	75	27	509	2,600	14,050	19,840	0.54	40	3.3	300733
FN 473 M	45	78	27	588	2,500	14,128	19,896	0.58	45	3.8	306530
FN 473 Z	45	78	27	544	2,500	14,128	19,896	0.58	45	3.8	306531

The specified nominal torque is based on sufficient stiffness of mating parts (Pg. 22) and refers to the integrated insert element, not the key way.

Rotation speed n = insert element's inherent speed (Pg. 57)