

Complete Freewheel Clutch Unit FND

with seals and keyway (IR)



Characteristics

Width
34 mm

Operating temperature
max. 100°C

Lubrication

Operative lifetime oil lubrication

Installation

Installation tolerances
Shaft js6 (k5); hub H6

Mating parts

Hardening and grinding of the mating parts is not necessary. Thoroughly clean (grease free) the mating parts in the vicinity of the freewheel clutch as well as the freewheel clutch's rings before making the press fit.

Bearing

The freewheel clutch includes ball and roller bearings. Additional external bearing support is not necessary.

Press fit pressure

Press fit pressure must not be applied to the balls.

Clamping direction

The arrow on the inner ring designates the inner ring's clamping direction.

Components

Freewheel clutch insert element* FE 400 M (meander spring)
FE 400 Z (tension spring)

+ Raceways Bearing steel, hardened and ground
inner ring Keyway per DIN 6885, Sheet 1
Tolerance: P9 with back clearance
outer ring Press fit

+ Ball bearing Integrated

+ Roller bearing RL 400

+ Lubrication Lifetime oil lubrication

+ Seal GMN rubber seal

* available with either freewheel clutch insert element FE 400 M (meander spring) or FE 400 Z (tension spring).

Data

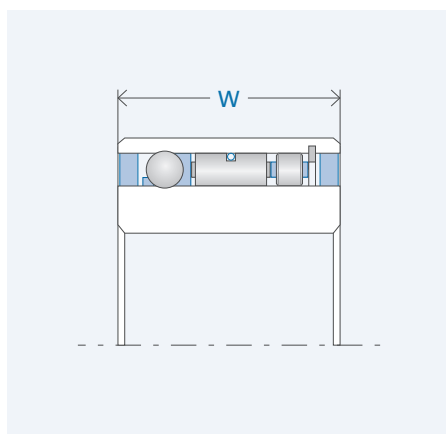
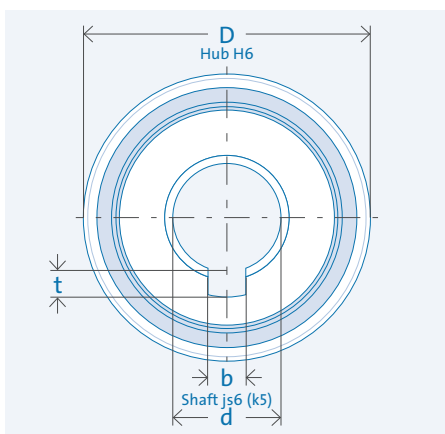

Drawing legend

- d = inner diameter
- D = outer diameter
- W = width
- T = torque
- n = rotation speed
- C = load capacity
- b = keyway width
- t = keyway depth

Designation	d [mm]	D [mm]	W [mm]	T _{nom} [Nm]	n _{max} [rpm]	C _{dyn.} [N]	C _{stat.} [N]	Weight [kg]	b [mm]	t [mm]	Item no.
FND 437 M	15	41	34	176	1,700	8,962	8,661	0.24	5	2.3	300737
FND 437 Z	15	41	34	161	1,700	8,962	8,661	0.24	5	2.3	300738
FND 442 M	20	46	34	223	1,500	10,247	10,708	0.28	6	2.8	300743
FND 442 Z	20	46	34	208	1,500	10,247	10,708	0.28	6	2.8	300744
FND 453 M	25	58	34	343	1,200	11,417	13,577	0.46	8	3.3	300751
FND 453 Z	25	58	34	314	1,200	11,417	13,577	0.46	8	3.3	300752
FND 459 M	30	64	34	411	1,100	12,691	16,320	0.55	8	3.3	300758
FND 459 Z	30	64	34	381	1,100	12,691	16,320	0.55	8	3.3	300760
FND 463 M	35	68	34	462	1,100	13,070	17,063	0.60	10	3.3	306528
FND 463 Z	35	68	34	428	1,100	13,070	17,063	0.60	10	3.3	306529
FND 470 M	40	75	34	550	1,000	14,050	19,840	0.69	12	3.3	300765
FND 470 Z	40	75	34	509	1,000	14,050	19,840	0.69	12	3.3	300766
FND 473 M	45	78	34	588	1,000	14,128	19,896	0.73	14	3.8	306532
FND 473 Z	45	78	34	543	1,000	14,128	19,896	0.73	14	3.8	306533

The specified nominal torque is based on sufficient stiffness of mating parts (Pg. 22) and refers to the integrated insert element, not the key way.

Rotation speed n = speed difference of mating parts