

CLAMPEX® KTR 203 and KTR 206

Clamping elements

Self-centering clamping elements as a compact alternative to KTR 200/201

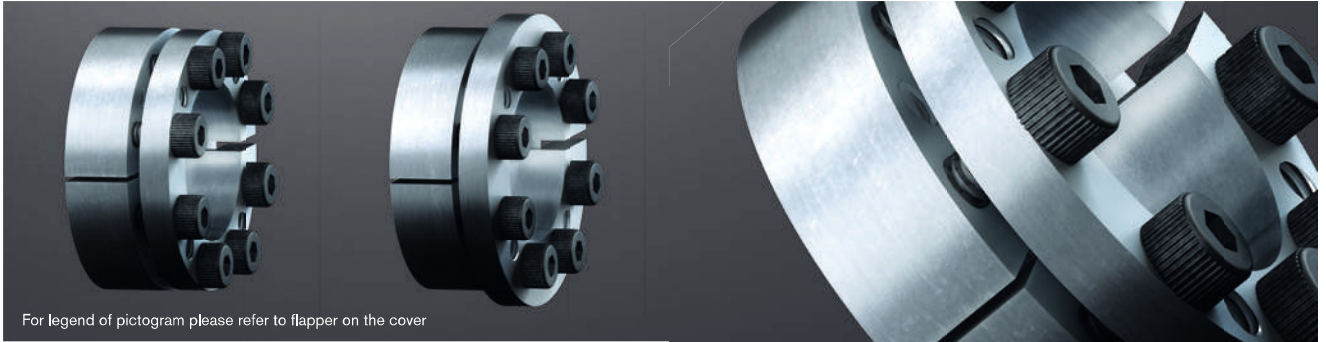

For legend of pictogram please refer to flapper on the cover

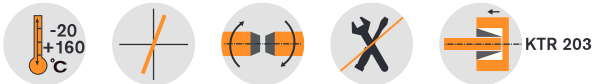

KTR 203

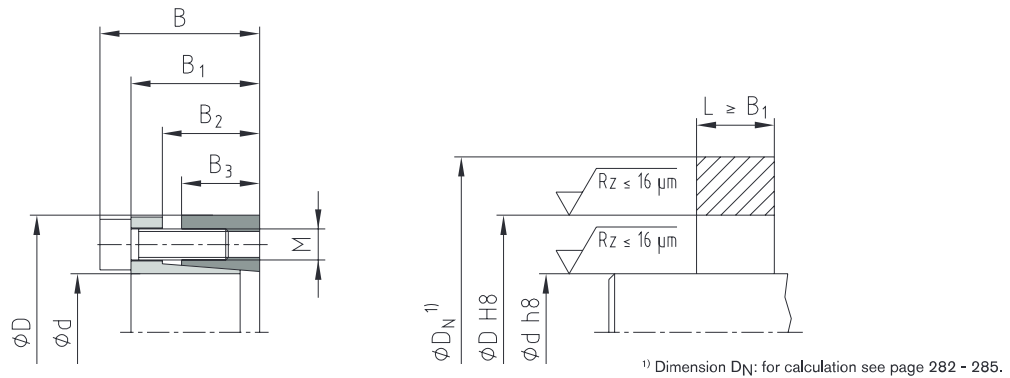

Example of application of hub design

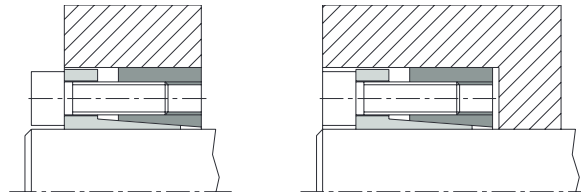

KTR 206

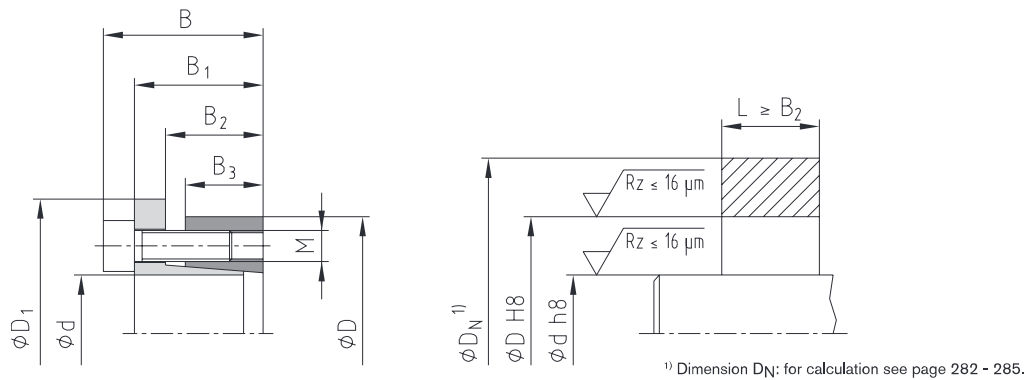

Example of application of hub design

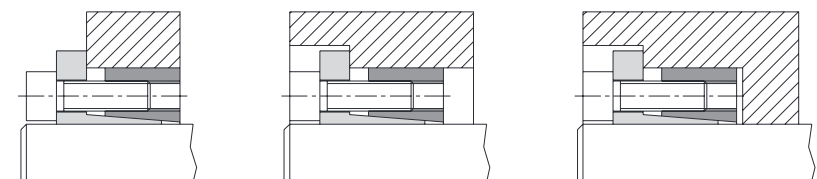

Ordering example:

KTR 203	40	x	65
Series	Size of internal diameter d		Size of external diameter D

CLAMPEX® – KTR 203 and KTR 206

d x D [mm]	Dimensions [mm] B B ₁ B ₂ B ₃ D ₁					Clamping screws DIN EN ISO 4762 - 12.9 μ _{total} =0.14 z = number T _A [Nm] ¹⁾ KTR 203 KTR 206					KTR 203						KTR 206					
											Transmittable torque or axial force		Surface pressure between clamping element		Weight [-kg]	Stock programme	Transmittable torque or axial force		Surface pressure between clamping element		Weight [-kg]	Stock programme
											T [Nm]	F _{ax} [kN]	Shaft P _W [N/mm ²]	Hub P _N [N/mm ²]			T [Nm]	F _{ax} [kN]	Shaft P _W [N/mm ²]	Hub P _N [N/mm ²]		
NEW 18 x 47	34	28	22	17	53	M6	20	6	14	17	370	41	356	136	0.3		290	32	279	107	0.3	
NEW 19 x 47	34	28	22	17	53	M6	20	6	14	17	390	41	337	136	0.3		300	32	259	105	0.3	
20 x 47	34	28	22	17	53	M6	20	6	14	17	410	41	320	136	0.3	●	320	32	250	106	0.3	●
22 x 47	34	28	22	17	53	M6	20	6	14	17	450	41	290	136	0.3	●	350	32	226	106	0.3	●
24 x 50	34	28	22	17	56	M6	20	6	14	17	490	41	265	127	0.3	●	390	33	211	101	0.3	●
25 x 50	34	28	22	17	56	M6	20	6	14	17	510	41	255	127	0.3	●	400	32	200	100	0.3	●
28 x 55	34	28	22	17	61.4	M6	20	6	14	17	570	41	227	116	0.3	●	450	32	179	91	0.4	●
30 x 55	34	28	22	17	61.4	M6	20	6	14	17	610	41	212	115	0.3	●	490	33	170	93	0.3	●
32 x 60	34	28	22	17.5	67	M6	20	8	14	17	880	55	261	139	0.4	●	700	44	207	111	0.3	●
35 x 60	34	28	22	17.5	67	M6	20	8	14	17	960	55	238	139	0.3	●	760	43	188	110	0.4	●
38 x 65	34	28	22	17.5	72	M6	20	8	14	17	1000	53	210	123	0.4	●	820	43	172	101	0.5	●
40 x 65	34	28	22	17.5	72	M6	20	8	14	17	1100	55	208	128	0.4	●	870	44	165	101	0.4	●
42 x 75	41	33	25	20	84	M8	25	8	35	41	2200	105	331	185	0.6	●	1700	81	256	143	0.7	●
45 x 75	41	33	25	20	84	M8	25	8	35	41	2400	107	314	189	0.6	●	1800	80	236	141	0.7	●
48 x 80	41	33.5	24	20	89	M8	25	8	35	41	2500	104	288	173	0.7	●	1900	79	219	131	0.8	●
50 x 80	41	33.5	24	20	89	M8	25	8	35	41	2600	104	276	172	0.7	●	2000	80	212	133	0.8	●
55 x 85	41	33.5	24	20	94	M8	25	8	35	41	2900	105	254	165	0.7	●	2200	80	193	125	0.9	●
60 x 90	41	33.5	24	20	99	M8	25	8	35	41	3100	103	228	152	0.8	●	2400	80	177	118	0.9	●
65 x 95	41	33.5	24	20	104	M8	25	8	35	41	3400	105	213	146	0.8	●	2600	80	163	112	0.9	●
70 x 110	50	40	29	24	119	M10	30	8	70	83	6000	171	271	172	1.5	●	4600	131	208	132	1.6	●
75 x 115	50	40	29	24	124	M10	30	8	70	83	6400	171	252	164	1.6	●	5000	133	196	128	1.7	●
80 x 120	50	40	29	24	129	M10	30	8	70	83	6800	170	235	157	1.7	●	5300	133	183	122	1.9	●
85 x 125	50	40	29	24	134	M10	30	10	70	83	9000	212	275	187	1.8	●	7000	165	214	146	2.0	●
90 x 130	50	40	29	24	139	M10	30	10	70	83	9600	213	262	181	1.9	●	7400	164	202	140	2.0	●
95 x 135	50	40	29	24	144	M10	30	10	70	83	10200	215	250	176	2.0	●	7800	164	191	134	2.3	●
100 x 145	56	44	31	25.5	154	M12	30	8	115	145	12000	240	250	172	2.6	●	9700	194	202	139	2.8	●
110 x 155	56	44	31	25.5	164	M12	30	8	115	145	13000	236	224	159	2.8	●	10700	195	184	131	3.1	●
120 x 165	56	44	31	26	174	M12	30	9	115	145	16000	267	227	165	3.6	●	13100	218	186	135	3.2	●
130 x 180	64	52	39	34	189	M12	30	12	115	145	23000	354	212	153	4.4	●	19000	292	175	127	4.6	●
140 x 190	68	54	39	34	199	M14	40	9	185	230	25000	357	199	147	4.9	●	20500	293	163	120	5.0	●
150 x 200	68	54	39	34	209	M14	40	10	185	230	30000	400	208	156	5.2	●	24500	327	170	127	5.2	●
160 x 210	68	54	39	34	219	M14	40	12	185	230	38800	485	236	180	5.6	●	31300	391	191	145	5.6	●
170 x 225	78	64	49	44	234	M14	40	12	185	230	41300	486	172	130	6.9	●	33200	391	139	105	6.5	●
180 x 235	78	64	49	44	244	M14	40	12	185	230	43700	486	163	125	8.5	●	35000	389	130	100	8.5	●
190 x 250	78	64	49	43.5	259	M14	40	15	185	230	57700	607	195	148	9.0	●	46500	489	157	119	9.0	●
200 x 260	78	64	49	43.5	269	M14	40	15	185	230	60700	607	185	142	9.6	●	49000	490	149	115	9.6	●
220 x 285	88	72	57	50	294	M16	40	12	290	360	77300	703	169	131	13.4	●	57100	519	125	97	14.0	●
240 x 305	88	72	57	50	314	M16	40	15	290	360	105400	878	194	153	14.5	●	77800	648	143	113	15.1	●
260 x 325	88	72	57	50	334	M16	40	18	290	360	137000	1054	215	172	16.1	●	101200	778	159	127	16.2	●
280 x 355	102	84	66	60	364	M18	50	16	400	480	160300	1145	181	143	23.4	●	113300	809	128	101	25.6	●
300 x 375	102	84	66	60	384	M18	50	18	400	480	193200	1288	190	152	25.3	●	136500	910	134	107	25.5	●
320 x 405	121	101	81	74	414	M20	50	18	580	690	269300	1683	189	149	36.9	●	191000	1194	134	106	37.9	●
340 x 425	121	101	81	74	434	M20	50	21	580	690	333800	1964	207	166	39.0	●	237000	1394	147	118	38.3	●
NEW 360 x 455	138	116	93	86	464	M22	60	18	780	930	375700	2087	179	141	54.0	●	264000	1467	126	99	53.3	●
NEW 380 x 475	138	116	93	86	484	M22	60	21	780	930	462700	2435	198	158	56.2	●	325000	1711	139	111	57.6	●
NEW 400 x 495	138	116	93	86	504	M22	60	21	780	930	487000	2435	188	152	58.9	●	342000	1710	132	107	60.3	●

● Sizes of clamping elements available from stock.

¹⁾ These are the maximum screw tightening torques. They can be reduced by a maximum of 40 % of the above-mentioned figures with T, F_{ax}, P_W and P_N decreasing proportionately.