

POLY-NORM® Flexible couplings

Technical data

POLY-NORM® Technical data													
Size	Torque [Nm]			Max. speed [rpm] with v = 35 m/s	Torsion angle with		Torsion spring stiffness C dyn. [Nm/rad]				Max. perm. displacement [mm] ¹⁾		
	Rated torque T _{KN}	Maximum torque T _{K max}	Vibratory torque T _{KW}		T _{KN}	T _{K max}	1.0 T _{KN}	0.75 T _{KN}	0.5 T _{KN}	0.25 T _{KN}	Axial ΔK _a	Radial ΔK _r	Angular ΔK _w
28	40	80	16	9650			0.52x10 ⁴	0.332x10 ⁴	0.187x10 ⁴	0.09x10 ⁴	± 1.0	0.20	1.2
32	60	120	24	8550	4.5	6.0	0.782x10 ⁴	0.499x10 ⁴	0.282x10 ⁴	0.135x10 ⁴	± 1.0	0.25	1.4
38	90	180	36	7650			1.35x10 ⁴	0.864x10 ⁴	0.489x10 ⁴	0.234x10 ⁴	± 1.0	0.25	1.5
42	150	300	60	6950			2.63x10 ⁴	1.68x10 ⁴	0.947x10 ⁴	0.453x10 ⁴	± 1.0	0.25	1.7
48	220	440	88	6300			2.99x10 ⁴	1.91x10 ⁴	1.08x10 ⁴	0.516x10 ⁴	± 1.5	0.30	1.8
55	300	600	120	5650			3.85x10 ⁴	2.46x10 ⁴	1.39x10 ⁴	0.664x10 ⁴	± 1.5	0.30	2.0
60	410	820	164	5150	4.0	5.5	6.76x10 ⁴	4.31x10 ⁴	2.32x10 ⁴	1.17x10 ⁴	± 1.5	0.30	2.2
65	550	1100	220	4750			8.18x10 ⁴	5.22x10 ⁴	2.7x10 ⁴	1.41x10 ⁴	± 1.5	0.35	2.4
75	850	1700	340	4200			12.29x10 ⁴	7.84x10 ⁴	4.06x10 ⁴	2.12x10 ⁴	± 1.5	0.40	2.7
85	1350	2700	540	3650			24.31x10 ⁴	15.51x10 ⁴	7.49x10 ⁴	4.19x10 ⁴	± 1.5	0.40	3.0
90	2000	4000	800	3300			36.16x10 ⁴	23.07x10 ⁴	11.14x10 ⁴	6.24x10 ⁴	± 1.5	0.45	3.4
100	2900	5800	1160	2950			54.82x10 ⁴	34.98x10 ⁴	16.89x10 ⁴	9.46x10 ⁴	± 3.0	0.50	3.9
110	3900	7800	1560	2650			79.23x10 ⁴	50.55x10 ⁴	24.4x10 ⁴	13.67x10 ⁴	± 3.0	0.60	4.3
125	5500	11000	2200	2350	2.5	3.5	102.3x10 ⁴	65.28x10 ⁴	31.52x10 ⁴	17.65x10 ⁴	± 3.0	0.60	4.8
140	7200	14400	2880	2100			164x10 ⁴	104.7x10 ⁴	50.85x10 ⁴	28.3x10 ⁴	± 3.0	0.60	5.5
160	10000	20000	4000	1900			209.1x10 ⁴	133.4x10 ⁴	64.82x10 ⁴	36.07x10 ⁴	± 3.0	0.65	6.1
180	13400	26800	5360	1650			267.1x10 ⁴	170.4x10 ⁴	82.79x10 ⁴	46.07x10 ⁴	± 3.0	0.65	6.0
200	19000	38000	7600	1450			359.5x10 ⁴	226.2x10 ⁴	109.2x10 ⁴	60.2x10 ⁴	± 4.0	0.65	7.8
220	30000	60000	12000	1300			513.8x10 ⁴	325.1x10 ⁴	156.1x10 ⁴	84.4x10 ⁴	± 4.0	0.70	8.7
240	43000	86000	17200	1200	1.5	2.1	697.9x10 ⁴	438.3x10 ⁴	209.1x10 ⁴	111.9x10 ⁴	± 4.0	0.70	9.6
260	55000	110000	22000	1000			923.6x10 ⁴	589.7x10 ⁴	282.8x10 ⁴	145.3x10 ⁴	± 4.0	0.85	11.3
280	67000	134000	26800	950			1221.8x10 ⁴	773.1x10 ⁴	377.9x10 ⁴	191.6x10 ⁴	± 4.0	0.95	12.2

¹⁾ Displacement with n = 1500 rpm

Radial and angular displacements may occur simultaneously. The combined sum of displacements must not exceed the values listed in the table. If requested, coupling is dynamically balanced (semi-key balancing G 6.3 with 1500 rpm). For circumferential speeds exceeding v = 20 m/s dyn. balancing is recommended.

Axial displacement ΔK_a

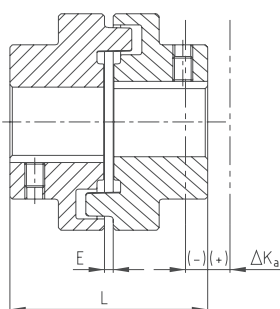

$$L_{\max./\min.} = L + \Delta K_a \text{ [mm]}$$

Radial displacement ΔK_r

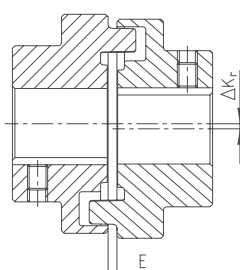

Angular displacement ΔK_w

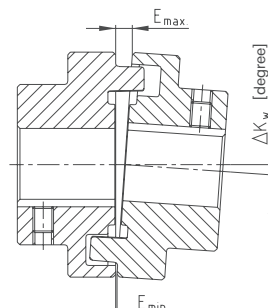

$$\Delta K_w = E_{\max.} - E_{\min.} \text{ [mm]}$$

Advice for assembly

With assembly the coupling halves must be mounted in that coupling and shaft are flush. Alignment must be made in that radial and angular displacement is as small as possible. The service life of coupling and bearings is extended by accurate alignment. Steps must be taken to ensure that the alignment condition does not change during any operating condition. Shaft displacement which cannot be avoided should not exceed the figures specified in the table. Angular and radial displacement may occur simultaneously. The combined sum of displacements must not exceed the values listed in the table above. See KTR assembly instructions, KTR standard 49510 on our homepage www.ktr.com.

General information about the elastomer

Material/hardness	Perbunan [NBR]/78 Shore A
Permanent temperature range [°C]	-30 to +80
Max. temperature (short time) [°C]	-50 to +120
Operating range	General engineering Pump industry ATEX applications Chemical industry Standard applications with average elasticity
Resistant to	Gasoline, diesel Acids, bases Tropics (Salt) water (hot/cold) Oils, greases Propane, butane Natural gas, city gas



Elastomer ring NBR 78 Shore A

Elastomer ring Viton [FKM] 60 Shore A for the high-temperature range on request.

POLY-NORM® Flexible couplings

Selection of standard IEC motors

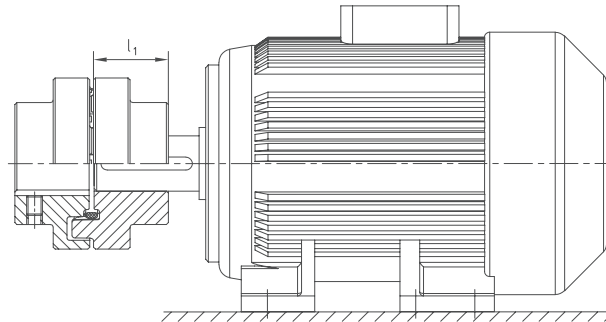

POLY-NORM® couplings for standard IEC motors, protection class IP 54/IP 55 (elastomer ring 78 Shore A)														
A. C. motor 50 Hz			Motor power n= 3000 rpm 2 poles		POLY-NORM® coupling size	Motor power n= 1500 rpm 4 poles		POLY-NORM® coupling size	Motor power n= 1000 rpm 6 poles		POLY-NORM® coupling size	Motor power n= 750 rpm 8 poles		POLY-NORM® coupling size
Size	Shaft end dcl [mm]		Power P [kW]	Torque T [Nm]		Power P [kW]	Torque T [Nm]		Power P [kW]	Torque T [Nm]		Power P [kW]	Torque T [Nm]	
56	9 x 20		0.09	0.32		0.06	0.43		0.037	0.43				
			0.12	0.41		0.09	0.64		0.045	0.52				
63	11 x 23		0.18	0.62		0.12	0.88		0.06	0.7				
			0.25	0.86		0.18	1.3		0.09	1.1				
71	14 x 30		0.37	1.3		0.25	1.8		0.18	2		0.09	1.4	
			0.55	1.9		0.37	2.5		0.25	2.8		0.12	1.8	
80	19 x 40		0.75	2.5	28/32	0.55	3.7	28/32	0.37	3.9	28/32	0.18	2.5	28/32
			1.1	3.7		0.75	5.1		0.55	5.8		0.25	3.5	
90S	24 x 50		1.5	5		1.1	7.5		0.75	8		0.37	5.3	
90L			2.2	7.4		1.5	10		1.1	12		0.55	7.9	
100L	28 x 60		3	9.8		2.2	15		1.5	15		0.75	11	
						3	20					1.1	16	
112M			4	13		4	27		2.2	22		1.5	21	
132S			5.5	18		5.5	36		3	30		2.2	30	
132M	38 x 80		7.5	25	38	7.5	49	38	4	40	38	3	40	38
									5.5	55				
160M	42 x 110		11	36		11	72		7.5	75	42	4	54	42
			15	49	42			42				5.5	74	
160L			18.5	60		15	98		11	109		7.5	100	
180M	48 x 110		22	71	48	18.5	121	48			48			48
180L						22	144		15	148		11	145	
200L	55 x 110		30	97		30	196		18.5	181	55	15	198	55
			37	120	55			55	22	215				55
225S	55 x 110					37	240				60	18.5	244	60
225M	60 x 140		45	145		45	292	60	30	293		22	290	60
250M	60 x 140		55	177	60	55	356	65	37	361	65	30	392	65
280S	75 x 140		75	241		75	484		45	438		37	483	
280M			90	289	65	90	581	75	55	535	75	45	587	75
315S			110	353		110	707		75	727		55	712	
315M	80 x 170		132	423		132	849	85	90	873	85	75	971	85
	65 x 140		160	513	75	160	1030		110	1070		90	1170	90
315L			200	641		200	1290	90	132	1280	90	110	1420	
					85				160	1550		132	1710	
315	85 x 170		250	802		250	1600		200	1930	100	160	2070	100
			315	1010		315	2020	100	250	2410	110	200	2580	110
			355	1140	90	355	2280		315	3040	125	250	3220	125
355	75 x 140		400	1280		400	2570	110	400	3850		315	4060	125
			500	1600		500	3210							
			560	1790	100	560	3580	125	450	4330	140	355	4570	140
400	80 x 170		630	2020		630	4030		500	4810		400	5150	
	110 x 210		710	2270	110	710	4540	140	560	5390	160	450	5790	160
			800	2560		800	5120		630	6060		500	6420	
450	90 x 170		900	2880	125	900	5760	160	710	6830		560	7190	180
	120 x 200		1000	3200		1000	6400		800	7690	180	630	8090	180

The coupling selection is based on an ambient temperature up to +30 °C. The selection is based on a minimum safety factor of 2 versus the max. coupling torque ($T_{K \max}$). A detailed selection is possible according to catalogue page 15 et seqq. Drives with periodical torque curves must be selected according to DIN 740 part 2. If requested, KTR will perform the selection.

Torque T = rated torque according to Siemens catalogue M 11 · 1994/95.

POLY-NORM® AR

Flexible couplings

Two-part

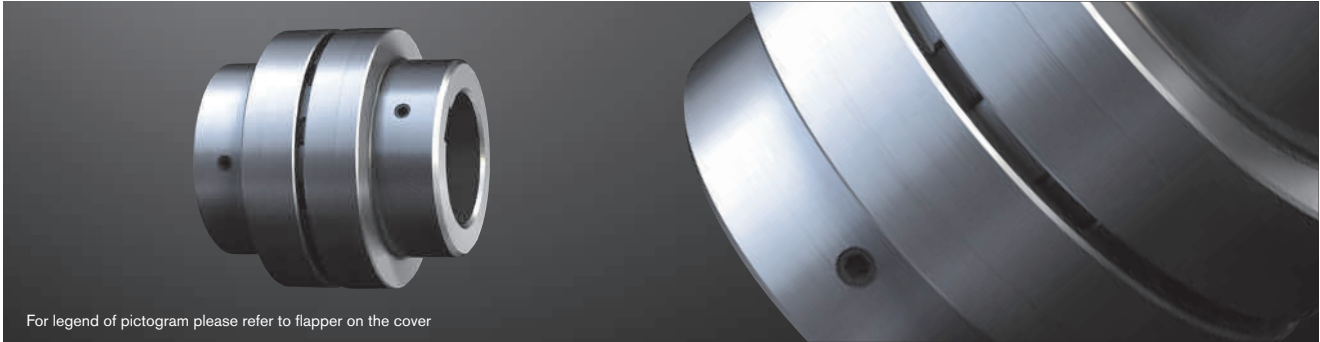

For legend of pictogram please refer to flapper on the cover

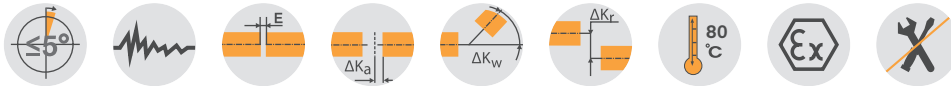

Components

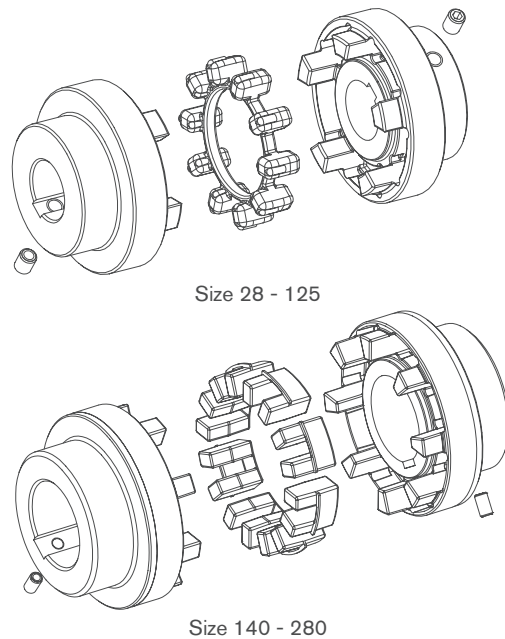
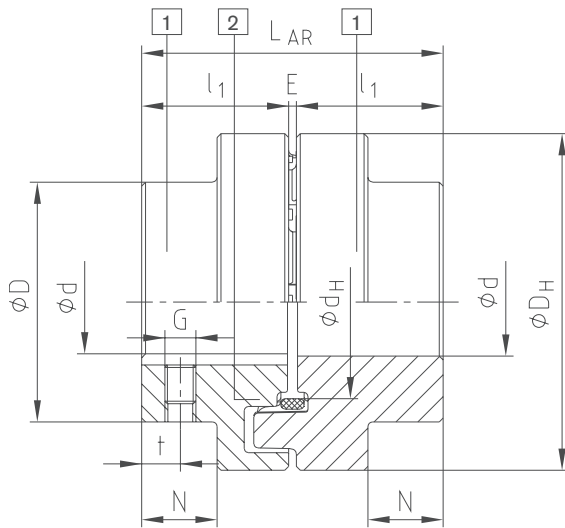

Components of type AR:
1 = Standard hub (GJL)
2 = Elastomer ring (up to size 180: NBR 78 ShA; from size 200: T-PUR® 84 ShA)

POLY-NORM® Type AR															
Size	Elastomer ring ¹⁾ component ²⁾ Torque [Nm]		Max. finish bore d ²⁾	Dimensions [mm]										Mass moment of inertia ³⁾ [kgm ²]	Weight ³⁾ [kg]
	TKN	TKmax.		General								Setscrew ²⁾			
				LAR	l ₁	E	D _H	D	d _H	N	G	t			
28	40	80	30	59	28	3	69	46	36.5	12	M5	7	0.0004	0.9	
32	60	120	35	68	32	4	78	53	41.5	14	M8	7	0.0008	1.4	
38	90	180	40	80	38	4	87	62	50	19.5	M8	10	0.0016	2.0	
42	150	300	45	88	42	4	96	69	55.5	20	M8	10	0.0026	2.7	
48	220	440	50	101	48	5	106	78	64	24	M8	15	0.0042	3.7	
55	300	600	60	115	55	5	118	90	73	29	M8	14	0.0070	5.5	
60	410	820	65	125	60	5	129	97	81	33	M8	15	0.0112	6.9	
65	550	1100	70	135	65	5	140	105	86	36	M10	20	0.0174	8.8	
75	850	1700	80	155	75	5	158	123	100	42.5	M10	20	0.028	13.5	
85	1350	2700	90	175	85	5	182	139	116	48.5	M10	25	0.052	19.5	
90	2000	4000	95	185	90	5	200	148	128	49	M12	25	0.090	23.2	
100	2900	5800	110	206	100	6	224	165	143	55	M12	25	0.160	31.9	
110	3900	7800	50-120	226	110	6	250	185	158	60	M16	30	0.317	38.0	
125	5500	11000	55-140	256	125	6	280	210	178	70	M16	35	0.570	55.2	
140	7200	14400	65-155	286	140	6	315	235	216	76.5	M20	35	1.030	92.6	
160	10000	20000	75-175	326	160	6	350	265	246	94.5	M20	45	1.746	126.9	
180	13400	26800	75-200	366	180	6	400	300	290	111.5	M20	50	3.239	181.8	
200	19000	38000	85-200	408	200	8	450	335	-	126	M24	50	5.728	263.7	
220	30000	60000	95-220	448	220	8	500	370	-	140	M24	50	9.489	355.9	
240	43000	86000	105-240	488	240	8	550	405	-	154	M24	50	14.963	466.3	
260	55000	110000	115-260	530	260	10	650	440	-	158	M24	60	29.504	672.2	
280	67000	134000	125-280	570	280	10	700	475	-	172	M24	60	42.451	836.6	

¹⁾ Standard material Perbunan [NBR] 78 Shore A, size 140 - 280 double tooth elastomers, for selection see page 14 et seqq.

²⁾ Bores H7 with keyway to DIN 6885 sheet 1 [JS9] and setscrew on the keyway

³⁾ Referring to average bore

POLY-NORM® AR Flexible couplings

For taper clamping sleeve

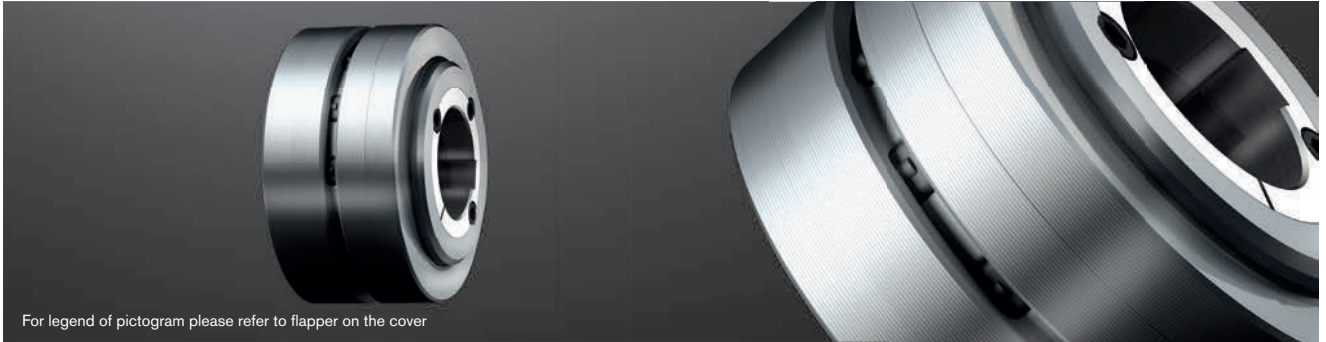

For legend of pictogram please refer to flapper on the cover



Components

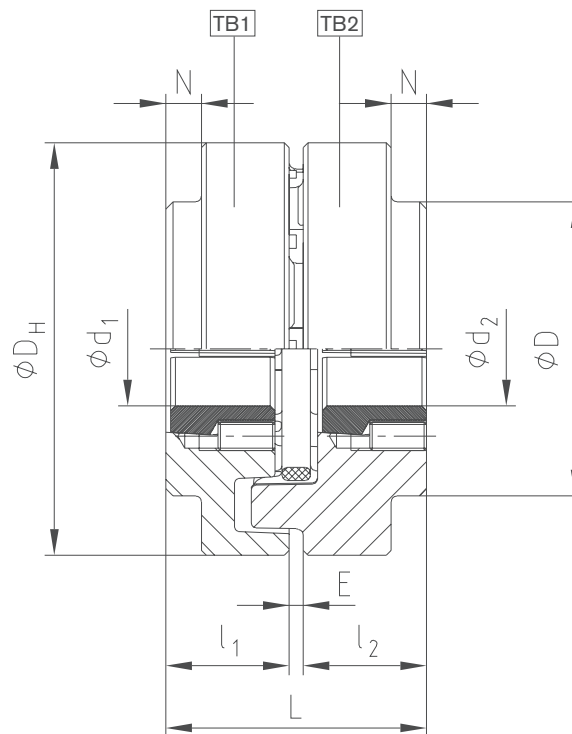

POLY-NORM® for taper clamping sleeve															
Size	Taper clamping sleeve	Dimensions [mm]		Fastening screws ¹⁾ for taper clamping sleeve				Size	Taper clamping sleeve	Dimensions [mm]		Fastening screws ¹⁾ for taper clamping sleeve			
		Max. d1, d2	l1, l2	Size [Inch]	Length [mm]	SW [mm]	TA [Nm]			Max. d1, d2	l1, l2	Size [Inch]	Length [mm]	SW [mm]	TA [Nm]
32	1108	25	25.5	1/4"	13	3	5.7	75	2517	60	52.5	1/2"	25	6	49
42	1210	32	31.0	3/8"	16	5	20	85	2517	60	46.5	1/2"	25	6	49
48	1610	40	30.0	3/16"	16	5	20		3030	75	82	5/8"	32	8	90
	1615	40	42.5	3/8"	16	5	20	3020	75	52.0	5/8"	32	8	92	
60	2012	50	38.5	7/16"	22	6	31	100	3535	90	98.0	1/2"	38	10	115
65	2517	60	62.5	1/2"	25	6	49	125	4040	100	111.5	5/8"	45	12	172

¹⁾ Each 2 fastening screws, with 3535/4040 3-off
For coupling type TB1 screwing on cam side - TB2 screwing on collar side
Combination possible! Please order our separate dimension sheet (M407045).

Ordering example:	POLY-NORM® 38	AR	Ø38	Ø30
	Coupling size	Type	Finish bore	Finish bore

POLY-NORM® ADR Flexible couplings

Three-part

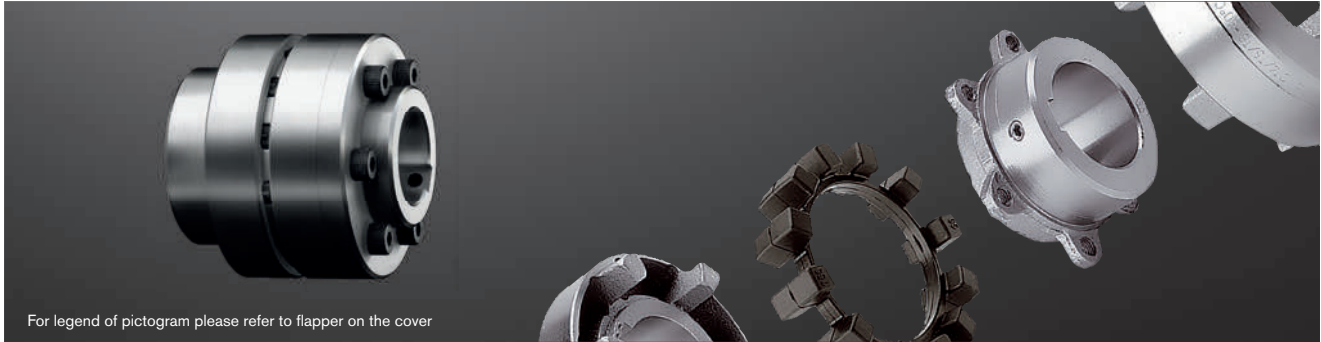

For legend of pictogram please refer to flapper on the cover



Components

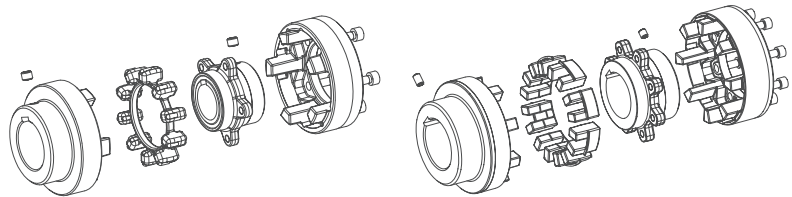
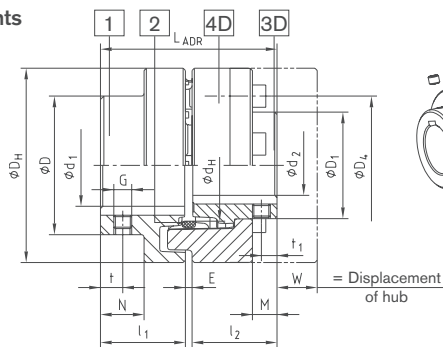

Size 38 - 125

Size 140 - 280

- Components of type ADR (three-part):
 1 = Standard hub* (GJL)
 2 = Elastomer ring (up to size 180: NBR 78 ShA; from size 200: T-PUR® 84 ShA)
 3D = Flange hub (GJS); 4D = Cam ring (GJL)
 * To be used preferably on driving side

POLY-NORM® Type ADR

Size	Elastomer ring ¹⁾ (component 2) Torque [Nm]		Dimensions [mm]															
			Max. finish bore ²⁾		General										Setscrew			
	TKN	TK max	d ₁	d ₂	L _{ADR}	l ₁ , l ₂	E	D _H	D	D ₁	d _H	N	M	W	G	t	t ₁	T _A [Nm]
38	90	180	40	34	80	38	4	87	62	48	50	19.5	11.0	12	M8	10	7	10
42	150	300	45	38	88	42	4	96	69	54	55.5	20	12.0	16	M8	10	7	10
48	220	440	50	44	101	48	5	106	78	62	64	24	13.7	16	M8	15	7	10
55	300	600	60	50	115	55	5	118	90	72	73	29	18.7	15	M8	14	14	10
60	410	820	65	56	125	60	5	129	97	80	81	33	22.2	14	M8	15	15	10
65	550	1100	70	60	135	65	5	140	105	86	86	36	26.7	11	M10	20	20	17
75	850	1700	80	68	155	75	5	158	123	98	100	42.5	27.8	16	M10	20	20	17
85	1350	2700	90	78	175	85	5	182	139	112	116	48.5	33.7	18	M10	25	25	17
90	2000	4000	95	85	185	90	5	200	148	122	128	49	31.5	26	M12	25	25	40
100	2900	5800	110	95	206	100	6	224	165	136	143	55	37.5	28	M12	25	25	40
110	3900	7800	50-120	105	226	110	6	250	185	150	158	60	39.5	30	M16	30	30	80
125	5500	11000	55-140	115	256	125	6	280	210	168	178	70	48.0	35	M16	35	35	80
140	7200	14400	65-155	55-135	286	140	6	315	235	195	216	76.5	47.0	59	M20	35	35	140
160	10000	20000	75-175	65-155	326	160	6	350	265	225	246	94.5	65.0	43	M20	45	45	140
180	13400	26800	75-200	65-175	366	180	6	400	300	255	290	111.5	79.0	33	M20	50	50	140
200	19000	38000	85-200	73-200	408	200	8	450	335	290	320	126	95	7	M24	50	50	240
220	30000	60000	95-220	83-220	448	220	8	500	370	320	354	140	103	8	M24	50	50	240
240	43000	86000	105-240	93-240	488	240	8	550	405	350	388	154	119	1	M24	50	50	240
260	55000	110000	115-260	103-260	530	260	10	650	440	380	445	158	109	34	M24	60	60	240
280	67000	134000	125-280	113-280	570	280	10	700	475	410	478	172	109	29	M24	60	60	240

Selection of cap screws DIN EN ISO 4762 - 12.9

Size	M x l [mm]	z = number	Pitch z x angle	D ₄ [mm]	T _A [Nm] ³⁾	Size	M x l [mm]	z = number	Pitch z x angle	D ₄ [mm]	T _A [Nm] ³⁾
38	M6x16	5	5x72	62	10	110	M16x40	8	8x45	183	210
42	M8x16	5	5x72	69	25	125	M20x40	8	8x45	202	410
48	M8x20	6	6x60	78	25	140	M20x50	8	8x45	237	410
55	M8x20	6	6x60	88	25	160	M20x55	9	9x40	267	410
60	M8x20	6	6x60	98	25	180	M20x60	10	10x36	304	410
65	M10x20	6	6x60	104	49	200	M20x60	10	10x36	342	580
75	M10x25	6	6x60	120	49	220	M24x70	10	10x36	378	1000
85	M12x25	6	6x60	138	86	240	M27x70	10	10x36	416	1500
90	M16x30	6	6x60	149	210	260	M30x90	10	10x36	480	2000
100	M16x30	6	6x60	163	210	280	M30x90	10	10x36	520	2000

¹⁾ Standard material Perbunan [NBR] 78 Shore A, size 140 - 280 double tooth elastomers, for selection see page 14 et seqq.

²⁾ Bores H7 with keyway to DIN 6885 sheet 1 [JS9] and setscrew ³⁾ Screw tightening torques acc. to 8.8

Ordering example:

POLY-NORM® 65	ADR	d ₁ = Ø55	d ₂ = Ø60
Coupling size	Type	Finish bore	Finish bore

POLY-NORM® BTA and SBA Flexible couplings

With brake drum/brake disk for brake stop



For legend of pictogram please refer to flapper on the cover

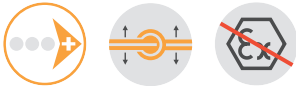
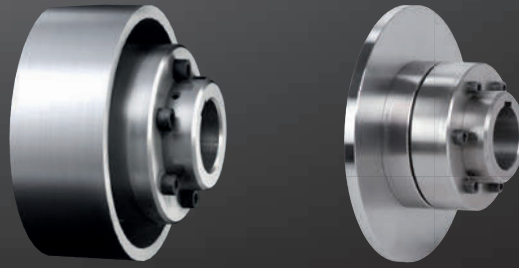

Components

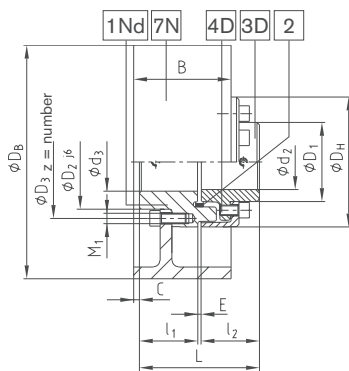

Brake drum type ADR-BTA

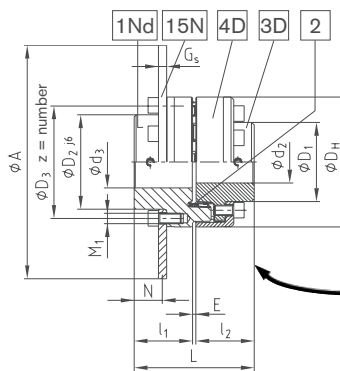

Brake disk type ADR-SBA

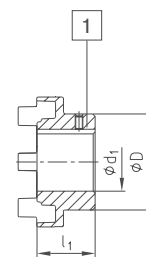

Flange hub 3D+4D interchangeable with standard hub 1

With standard hub type AR-BTA or AR-SBA

POLY-NORM® Type AR-BTA, AR-SBA, ADR-BTA and ADR-SBA														
Size	Elastomer ring ¹⁾ (component 2) Torque [Nm]		Dimensions [mm]											
	T _{KN}	T _K max	D, D ₁	Max. finish bore			D _H	D ₂	D ₃	z	M ₁	l _{1, 2}	E	L
d ₁	d ₂	d ₃												
38	90	180	For dimensions D, D ₁ please refer to our company catalogue on page 61 and 63	40	34	38	87	61	75	5 x 72°	M6	38	4	80
42	150	300		45	38	42	96	68	82	5 x 72°	M8	42	4	90
48	220	440		50	44	48	106	77	92	6 x 60°	M8	48	5	101
55	300	600		60	50	55	118	88	104	6 x 60°	M8	55	5	115
60	410	820		65	56	60	129	96	114	6 x 60°	M8	60	5	125
65	550	1100		70	60	65	140	104	122	6 x 60°	M10	65	5	135
75	850	1700		80	68	75	158	121	140	6 x 60°	M10	75	5	155
85	1350	2700		90	78	85	182	137	160	6 x 60°	M12	85	5	175
90	2000	4000		95	85	90	200	146	174	6 x 60°	M16	90	5	185
100	2900	5800		110	95	100	224	164	195	6 x 60°	M16	100	6	206
110	3900	7800		50-120	105	50-110	250	184	218	8 x 45°	M16	110	6	226
125	5500	11000		55-140	115	55-125	280	208	245	8 x 45°	M20	125	6	256
140	7200	14400		65-155	55-135	65-140	315	233	276	8 x 45°	M20	140	6	286
160	10000	20000		75-175	65-155	75-160	350	263	308	9 x 40°	M20	160	6	326
180	13400	26800		75-200	65-175	75-180	400	298	349	10 x 36°	M20	180	6	366

POLY-NORM® Type BTA														POLY-NORM® Type SBA																				
POLY-NORM® size	38	42	48	55	60	65	75	85	90	100	110	125	140	160	180	Max. speed [rpm] with v = 60 m/s ³⁾	POLY-NORM® size	38	42	48	55	60	65	75	85	90	100	110	125	140	160	180	Max. speed [rpm] with v = 60 m/s ³⁾	
ØD _B xB Brake drum ²⁾	Dimensions C [mm]															ØAxB Brake disk ²⁾	Dimensions N [mm]																	
160x60	4															7150	200x12.5	13.75														5725		
200x75	9	8	4													5725	250x12.5	13.75	14.75	18.75													4575	
250x95	17	16	20	7	3	0										4575	315x16		13	17	22	26	29	35.5								3625		
315x118		25	21	16	12	9	2.5	-3.5								3625	400x16			17	22	26	29	35.5	41.5	42	48					2850		
400x190			34	28	25	22	15.5	9.5	9	3						2850	500x16				22	26	29	35.5	41.5	42	48	54	64			2275		
500x190										18	12	-2				2275	630x20										46	52	62	69	86		1800	
630x236												20	13	-4		1800	710x20										46	52	62	69	86	104	1600	
710x265													24	7	-11	1600	800x25											43.5	49.5	59.5	66.5	83.5	101.5	1425
																	900x25												49.5	59.5	66.5	83.5	101.5	1250

¹⁾ Standard material Perbunan [NBR], for selection see page 14 et seqq.

²⁾ Steel ³⁾ Dynamic balancing required

Other sizes on request

Ordering example:	POLY-NORM® 38	ADR-BTA	Ø200 x 75	d ₂ = Ø32 NnD	d ₃ = Ø25 NnD
	Coupling size	Type	Brake drum Ø	Component with finish bore	Component with finish bore

POLY-NORM® ADR-SB

Flexible couplings

With brake disk for brake stop



For legend of pictogram please refer to flapper on the cover

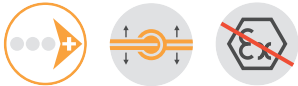

Components

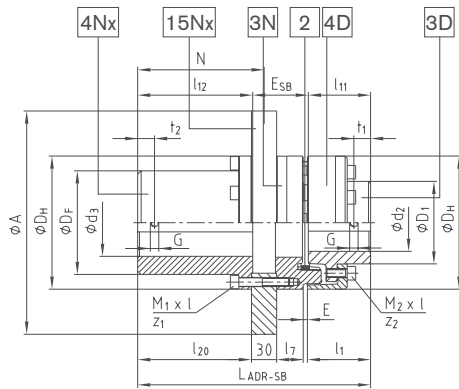

Type ADR-SB with brake disk

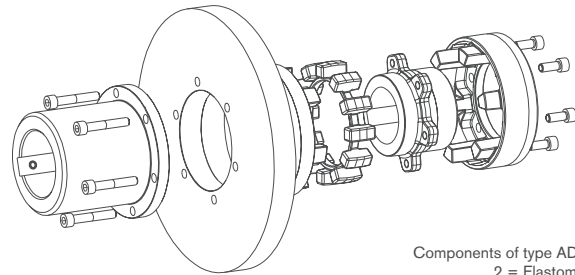

- Components of type ADR-SB:
 2 = Elastomer ring
 3D = Flange hub
 4D = Cam ring
 3N = Driving flange
 15Nx = Brake disk
 4Nx = Coupling flange

POLY-NORM® Type ADR-SB																			
Size	Elastomer ring ¹⁾ (component 2) Torque [Nm]		Max. finish bore		Dimensions [mm]											Setscrew			
	TKN	TK max	d ₂	d ₃	D _H	N	l ₂	E	l ₁₁	l ₁₂	DF	l ₇	l ₂₀	LADR-SB	D ₁	ESB	G	t ₁ , t ₂	T _A [Nm]
55	300	600	50	65	118	150	55	5	54.7	136.5	88	24.0	135	249.0	72	57.8	M8	15	10
60	410	820	56	70	129	150	50	5	59.2	136.5	97	25.0	135	255.0	80	59.3	M8	20	10
65	550	1100	60	75	140	150	65	5	63.7	136.5	105	26.5	135	261.5	86	61.3	M10	20	17
75	850	1700	68	90	158	150	75	5	74.0	136.5	123	31.5	135	276.5	98	66.0	M10	20	17
85	1350	2700	78	100	182	150	85	5	84.7	136.5	139	35.0	135	290.0	112	68.8	M10	25	17
90	2000	4000	85	110	200	150	90	5	89.5	136.5	148	39.5	135	299.5	122	73.5	M12	25	40
100	2900	5800	95	120	224	190	100	6	95.5	177.0	165	43.0	175	354.0	136	81.5	M12	25	40
110	3900	7800	105	135	250	190	110	6	105.5	177.0	185	48.0	175	369.0	150	86.5	M16	30	80
125	5500	11000	115	155	280	195	125	6	120.5	182.0	210	53.0	180	394.0	168	91.5	M16	35	80
140	7200	14400	135	170	315	195	140	6	130.0	182.0	235	60.5	180	416.5	195	104.5	M20	35	140
160	10000	20000	155	195	350	195	160	6	150.0	182.0	265	62.5	180	438.5	225	106.5	M20	45	140

Selection of brake disks and cap screws							
Size	ØA brake disk [mm]/ 30 mm thick ²⁾³⁾	Cap screws DIN EN ISO 4762 for brake disk			Cap screws DIN EN ISO 4762 for flange hub/cam ring		
		M ₁ x l	z ₁ = number	Tightening torque T _A [Nm]	M ₂ x l	z ₂ = number	Tightening torque T _A [Nm]
55	250 - 450	M8x20	6	10	M8x20	6	25
60	250 - 500	M8x20	6	10	M8x20	6	25
65	315 - 500	M8x55	6	35	M10x20	6	49
75	315 - 560	M10x60	6	69	M10x25	6	49
85	355 - 560	M10x60	6	69	M12x25	6	86
90	400 - 710	M12x65	6	120	M16x30	6	210
100	400 - 800	M12x65	6	120	M16x30	6	210
110	450 - 900	M16x75	8	295	M16x40	8	210
125	450 - 900	M16x75	8	295	M20x40	8	410
140	500 - 900	M20x80	8	410	M20x50	8	410
160	560 - 900	M20x90	9	410	M20x55	9	410

¹⁾ Standard material Perbunan [NBR], for selection see page 14 et seqq.

²⁾ Steel

³⁾ For circumferential speeds exceeding v = 20 m/s, dynamic balancing is required (referring to outside diameter ØD_H).

Maximum circumferential speed v = 60 m/s (referring to the diameter of brake disk ØA).

Other sizes on request

Ordering example:	POLY-NORM® 75	ADR-SB	Ø500 x 30	3D d ₂ = Ø60 keyway acc. to DIN	4Nx d ₃ = Ø70 keyway acc. to DIN
	Coupling size	Type	Brake disk ØA/ width	Component with finish bore	Component with finish bore

POLY-NORM® AZR

Flexible couplings

Standard drop-out center design coupling

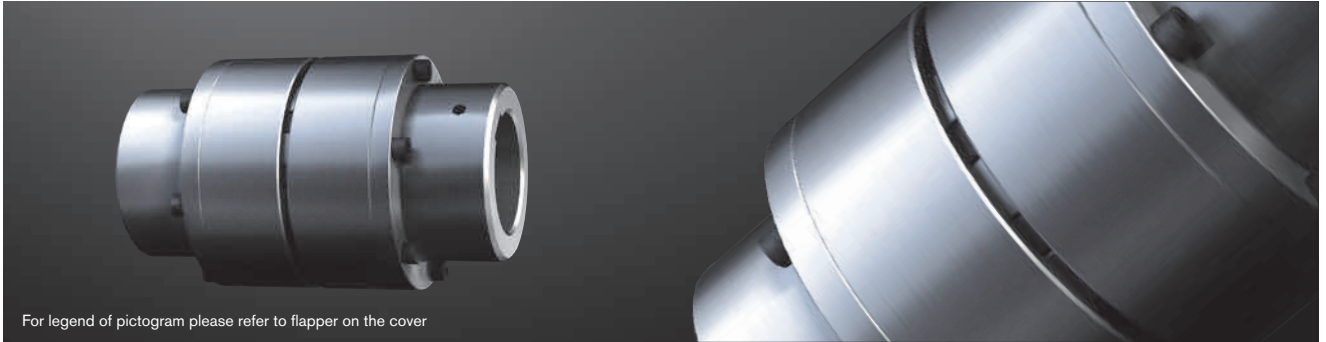

For legend of pictogram please refer to flapper on the cover



Components

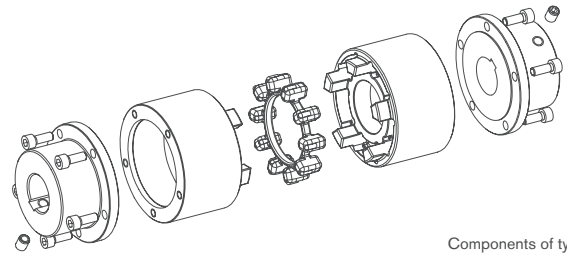
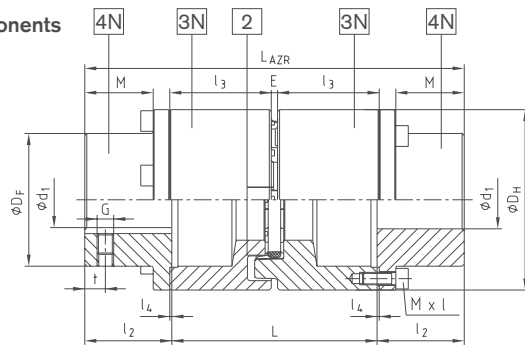

Components of type AZR:
 2 = Elastomer ring (NBR 78 ShA)
 3N = Driving flange (GJL)
 4N = Coupling flange (steel)

POLY-NORM® Type AZR																			
Size	Drop-out center length* L [mm]	Elastomer ring ¹⁾ (component 2) Torque [Nm]		Max. finish bore d ₁ ²⁾	Dimensions [mm]											Mass moment of inertia ³⁾ [kgm ²]	Weight ³⁾ [kg]		
		TKN	TK max		General													Setscrew	
					LAZR	l ₂	l ₃	E	l ₄	D _H	D _F	M	Mxl	T _A [Nm]	G			t	
28	100	40	80	34	170	35	49.5	3	1	69	46	26	M6x18	14	M5	7	0.0020	2.4	
	100				170	49	4	1	78	53	26	M6x18	14	M8	7	0.0042	3.2		
32	140	60	120	38	210	35	69	4	1	78	53	26	M6x18	14	M8	7	0.0062	3.9	
	100				184	42	49	4	1	87	62	33	M6x20	14	M8	10	0.0048	4.3	
38	140	90	180	45	224	42	69	4	1	96	69	35	M6x20	14	M8	10	0.0068	5.1	
	100				190	45	49	4	1	96	69	35	M6x20	14	M8	10	0.0094	5.1	
42	140	150	300	50	230	45	69	4	1	96	69	35	M6x20	14	M8	10	0.0128	6.0	
	100				204	52	49	5	1.5	106	78	41.5	M6x20	14	M8	15	0.0170	6.6	
48	140	220	440	55	244	52	69	5	1.5	106	78	41.5	M6x20	14	M8	15	0.0216	7.5	
	100				210	52	49	5	1.5	106	78	41.5	M6x20	14	M8	15	0.0188	9.4	
55	140	300	600	65	250	55	69	5	1.5	118	88	43.5	M8x25	35	M8	14	0.0240	10.8	
	180				290	55	89	5	1.5	118	88	43.5	M8x25	35	M8	14	0.0232	12.2	
60	100	410	820	70	220	60	49	5	1.5	129	97	47.5	M8x25	35	M8	15	0.0326	11.2	
	140				260	60	69	5	1.5	129	97	47.5	M8x25	35	M8	15	0.0414	13.0	
60	180	410	820	70	300	60	89	5	1.5	129	97	47.5	M8x25	35	M8	15	0.0504	14.6	
	100				230	60	49	5	1.5	129	97	47.5	M8x25	35	M8	15	0.0564	14.0	
65	140	550	1100	75	270	65	69	5	1.5	140	105	51.5	M8x25	35	M10	20	0.0730	15.8	
	180				310	65	89	5	1.5	140	105	51.5	M8x25	35	M10	20	0.0894	17.5	
65	140	550	1100	75	290	65	69	5	1.5	140	105	51.5	M8x25	35	M10	20	0.0824	23.2	
	180				330	75	89	5	1.5	158	123	60.5	M10x30	69	M10	20	0.1008	25.6	
75	250	850	1700	90	400	75	124	5	1.5	158	123	60.5	M10x30	69	M10	20	0.1332	29.8	
	140				310	75	69	5	1.5	158	123	60.5	M10x30	69	M10	20	0.1570	32.1	
85	180	1350	2700	100	350	85	89	5	1.5	182	139	69.5	M10x30	69	M10	25	0.1658	35.2	
	250				420	85	124	5	1.5	182	139	69.5	M10x30	69	M10	25	0.1812	40.7	
85	140	1350	2700	100	320	85	69	5	1.5	182	139	69.5	M10x30	69	M10	25	0.2466	38.2	
	180				360	90	89	5	1.5	200	148	73.5	M12x35	120	M12	25	0.2880	42.2	
90	250	2000	4000	110	430	90	124	5	1.5	200	148	73.5	M12x35	120	M12	25	0.3566	49.3	
	140				340	90	69	5	1.5	200	148	73.5	M12x35	120	M12	25	0.3988	50.0	
100	180	2900	5800	120	380	100	89	6	2	224	165	83	M12x35	120	M12	25	0.4450	54.8	
	250				450	100	124	6	2	224	165	83	M12x35	120	M12	25	0.5465	63.2	

¹⁾ Standard material Perbunan [NBR] 78 Shore A, for selection see page 14 et seqq.

²⁾ Bore H7 with keyway to DIN 6885 sheet 1 [JS9] and setscrew on the keyway

³⁾ Referring to average bore

*For other extendable lengths (L = 120/160/195/215) it is possible to combine two driving flanges 3N with various lengths. (As an example: driving flanges POLY-NORM® 85 for extendable length 140 and 250 produce an extendable length of 195 mm (140 mm + 250 mm = 390 mm; 390 mm/2 = 195 mm))

Ordering example:	POLY-NORM® 42	AZR	140	Ø38	Ø42
	Coupling size	Type	Drop-out center length L	Finish bore	Finish bore