

RADEX®-NC

Servo laminae couplings

Technical description

RADEX®-NC is a line specifically developed for servo technology. With this coupling a set of torsionally rigid steel laminas that are soft in bending ensure a reliable compensation for axial, angular and radial shaft displacements. As an all-metal coupling - the laminas are made of stainless steel - RADEX®-NC can even be used with high temperatures (up to 200 °C) and under aggressive ambient conditions. RADEX®-NC is manufactured in 10 sizes from size 5 to 75 for max. torques up to 4800 Nm. In addition to the two different designs (EK = single-cardanic and DK = double-cardanic) it is available in five different hub types.



A typical application of RADEX®-NC are backlash-free worm gear pairs with low gear ratios. For reason of the gear ratio of the gearbox the rigidity of the coupling must be converted from the drive side into the driven side. Here the gear ratio itself has a decisive influence because it is included in the calculation by square. This converted rigidity is added in line with the gearbox stiffness in order to obtain the total rigidity. In case of gear ratios that are smaller than $i = 8$ we recommend to use RADEX®-NC due to the loss of rigidity of the total system arising with the use of flexible couplings.

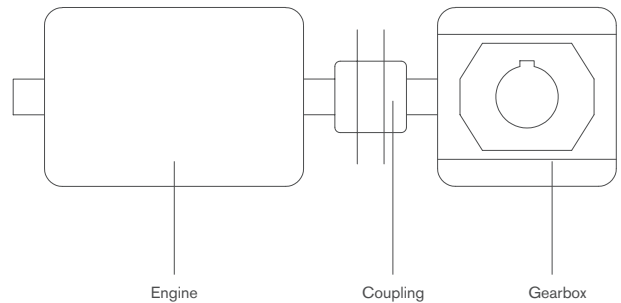

Use in potentially explosive atmospheres

RADEX®-NC couplings are suitable for power transmission in drives in potentially explosive atmospheres. The couplings are assessed and approved according to EU directive 2014/34/EU as units of category 2G/2D and thus suitable for the use in potentially explosive atmospheres of zone 1, 2, 21 and 22. Please read through our information included in the respective type examination certificate and the operating and assembly instructions at www.ktr.com.

Selection:

If used in potentially explosive atmospheres, the clamping hubs without feather keyway only for use in category 3 (with feather keyway for cat. 2) must be selected in that there is a minimum safety factor of $s = 2$ between the peak torque (including all operating parameters) and the nominal torque and frictional torque of engagement of the coupling.



RADEX®-NC DK and EK Servo laminae couplings

Laminae sets

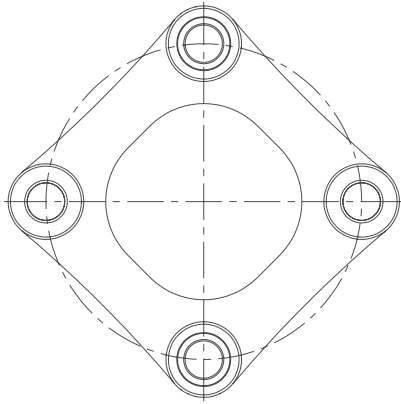

Size 5 to 26
(laminae with 4 holes)

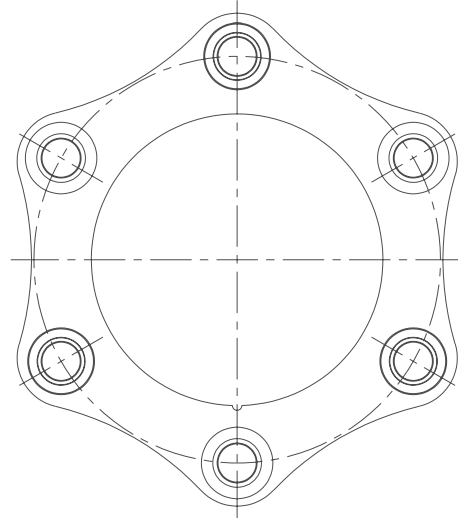

Size 36 to 75
(laminae with 6 holes)

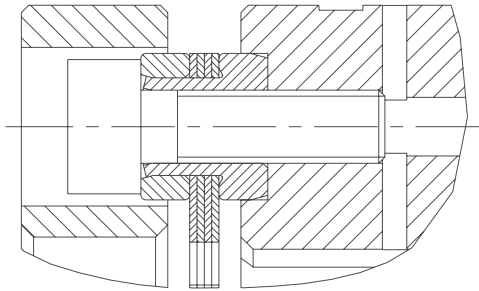

Size 5 to 10
(cylindrical sleeve)

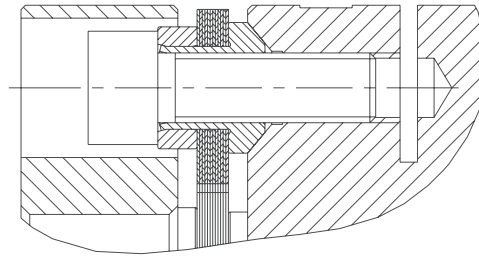

Size 16 to 75
(taper sleeve)

Types of hubs



Type 2.5 clamping hub
double slotted, without feather keyway
Frictionally engaged, backlash-free shaft-hub-connection.
Transmittable torques depending on bore diameter.



Type 2.6 clamping hub
double slotted, with feather keyway
Positive-locking power transmission with additional friction fit. The friction fit avoids or reduces reverse backlash. Surface pressure of the keyway connection is reduced.



Type 6.5 clamping ring hub
Integrated frictionally engaged shaft-hub-connection for the transmission of higher torques. Suitable for high speeds.

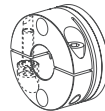

Type 3.5 clamping hub
triple slotted, without feather keyway
Frictionally engaged, backlash-free shaft-hub-connection, good properties of concentric running and reduced imbalance. Transmittable torques depending on bore diameter. Type 3.5 standard from size 43



Type 3.6 clamping hub
triple slotted, with feather keyway
Positive-locking power transmission with additional friction fit. The friction fit avoids or reduces reverse backlash. Surface pressure of the keyway connection is reduced. Type 3.6 standard from size 43

RADEX®-NC DK and EK Servo laminae couplings

Double- and single-cardanic types



For legend of pictogram please refer to flapper on the cover

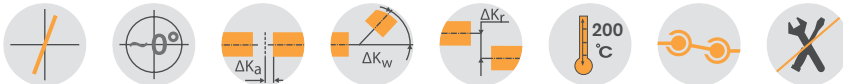

Hub type 2.5/2.6

Type DK

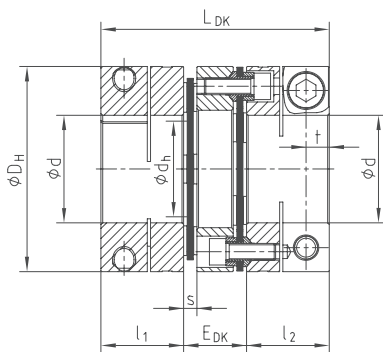

Type EK

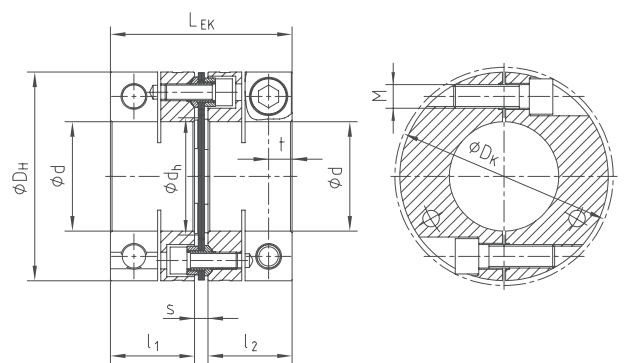

RADEX®-NC Types DK and EK - Hub and spacer material aluminium/laminas made of stainless steel

Size	Dimensions [mm]										Clamping screws DIN EN ISO 4762		Mass moment of inertia [kgm ²]	
	d _{max.}	DH	DK	l ₁ , l ₂	L _{DK}	E _{DK}	LEK	d _h	s	t	M	T _A [Nm]	DK	EK
5	12	26	26	12	34	10	26.5	12	2.5	3.5	M2.5	0.8	0.000004	0.000003
10	15	35	35	16	44	12	35	14.5	3	5	M4	3	0.000016	0.000012
16	20	46	49	22	58	14	47	19.5	3	6.8	M6	10	0.000063	0.00005
21	30	58	59	25	69	19	53.5	24	3.5	6.8	M6	10	0.00018	0.00014
26	38	69	73	32	88	24	69	30	5	9	M8	25	0.00046	0.00036
36	45	84	87	35	93.6	23.6	74.8	48	4.8	10.5	M10	49	0.0011	0.00091

Technical data

Size	T _{KN} ¹⁾ [Nm]	T _{K max} ¹⁾ [Nm]	Max. speed [rpm]	Torsion spring stiffness [Nm/rad]		Laminae type	Displacements of type DK			Displacements of type EK		
				EK	DK		Radial [mm]	Axial [mm]	Angular each laminae [degree]	Radial [mm]	Axial [mm]	Angular each laminae [degree]
5	2.5	5	18,300	2,400	1,200	4 holes	0.13	± 0.4	1	-	± 0.2	1
10	7.5	15	13,600	5,600	2,800	4 holes	0.16	± 0.8	1	-	± 0.4	1
16	35	53	10,500	20,000	10,000	4 holes	0.19	± 1.0	1	-	± 0.5	1
21	70	105	8,500	40,000	20,000	4 holes	0.27	± 1.2	1	-	± 0.6	1
26	120	180	7,000	84,000	42,000	4 holes	0.33	± 1.6	1	-	± 0.8	1
36	340	510	5,700	280,000	140,000	6 holes	0.32	± 2.0	1	-	± 1.0	1

¹⁾ For selection see page 22 et seqq.

Review of shaft-hub-connection: Friction torques T_R [Nm] for hub type 2.5

Size	Pilot bored	Ø3	Ø5	Ø8	Ø10	Ø12	Ø14	Ø15	Ø16	Ø19	Ø20	Ø22	Ø24	Ø25	Ø28	Ø30	Ø32	Ø35	Ø38	Ø40	Ø42	Ø45
5	2.5	1.1	1.8	2.8	3.4	4																
10	4.5		5	7.7	9.5	11.1	12.7	13.5														
16	5.5				23	27	31	33	35	41	43											
21	7.5					28	32	34	36	42	44	48	52	54	59	63						
26	9.5							66	70	81	85	92	100	103	114	121	127	137	147			
36	11.5									129	135	147	159	165	182	194	199	221	237	247	258	273

Ordering
example:

RADEX®-NC 21	DK	2.5 - Ø20		2.5 - Ø25	
Coupling size	Type	Hub type	Finish bore	Hub type	Finish bore

RADEX®-NC DK and EK Servo laminae couplings

Double- and single-cardanic types

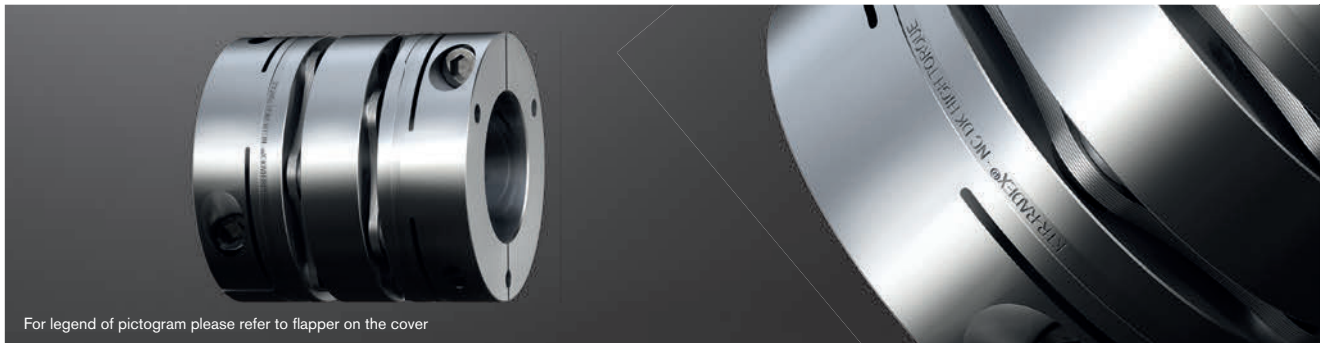

For legend of pictogram please refer to flapper on the cover

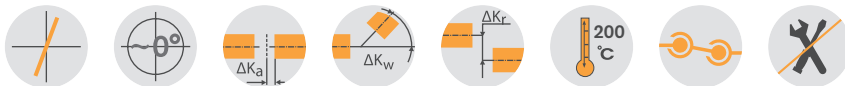

Hub type 3.5/3.6

Type DK

Type EK

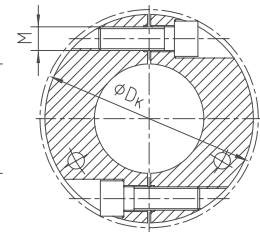
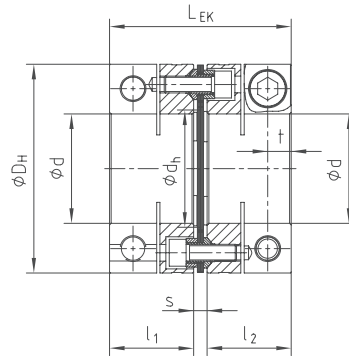
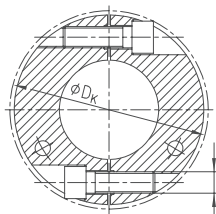
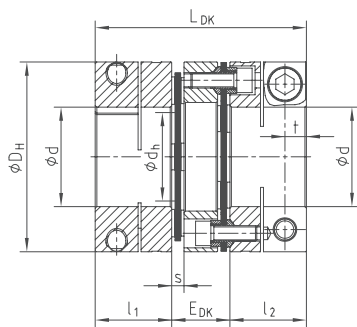

ROTEX® GS

Backlash-free
servo couplings

TOOLFLEX®

RADEX®-NC

COUNTEX®

RADEX®-NC Types DK and EK - Hub and spacer material aluminium up to size 61, steel with size 75 / laminae made of stainless steel

Size	Dimensions [mm]											Clamping screws DIN EN ISO 4762		Mass moment of inertia [kgm ²]	
	d _{max.}	D _H	DK	l ₁ , l ₂	L _{DK}	EDK	LEK	d _h	s	t	M	T _A [Nm]	DK	EK	
43	55	104	104	40.5	115	34	89	61	8	10.5	M10	49	0.0033	0.0025	
51	70	124	130	50	138	38	108	73	8	14	M14	135	0.0082	0.006	
61	80	144	148.5	54	150	42	118	88	10	16	M16	210	0.016	0.012	
75	90	170	181.1	70	189	49	152	104	12	21.5	M20	610	0.099	0.077	

Technical data

Size	T _{KN} ¹⁾ [Nm]	T _{K max} ¹⁾ [Nm]	Max. speed [rpm]	Torsion spring stiffness [Nm/rad]		Laminae type	Displacements of type DK			Displacements of type EK		
				Type EK	Type DK		Radial [mm]	Axial [mm]	Angular each laminae [degree]	Radial [mm]	Axial [mm]	Angular each laminae [degree]
43	600	900	8,100	510,000	255,000	6 holes	0.45	± 2.20	1	—	± 1.10	1
51	1,300	1,950	6,700	920,000	460,000	6 holes	0.52	± 2.50	1	—	± 1.25	1
61	2,000	3,000	6,100	1,500,000	750,000	6 holes	0.56	± 2.60	1	—	± 1.30	1
75	3,200	4,800	5,100	2,100,000	1,050,000	6 holes	0.64	± 2.90	1	—	± 1.45	1

¹⁾ For selection see page 22 et seqq.

Review of shaft-hub-connection: Friction torques T_R [Nm] for hub type 3.5

Size	Pilot bored	Ø24	Ø25	Ø28	Ø30	Ø32	Ø35	Ø38	Ø40	Ø42	Ø45	Ø48	Ø50	Ø55	Ø58	Ø60	Ø65	Ø70	Ø75	Ø80	Ø85	Ø90	
43	15.0	238	248	258	297	317	347	377	397	416	446	476	496	545									
51	28.0				594	633	693	752	792	831	891	950	990	1089	1148	1188	1286	1385					
61	30.0							1039	1093	1148	1230	1312	1367	1503	1585	1640	1777	1913	2050	2187			
75	35												3129	3192	3630	3755	4068	4381	4694	5006	5319	5632	

Ordering
example:

RADEX®-NC 43	DK	3.5 - Ø25			3.5 - Ø35		
Coupling size	Type	Hub type	Finish bore	Hub type	Finish bore	Hub type	Finish bore

RADEX®-NC DK and EK with clamping ring hubs Servo laminae couplings

Double- and single-cardanic types



For legend of pictogram please refer to flapper on the cover

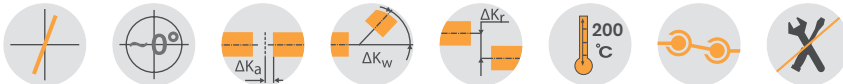

RADEX®-NC Types DK and EK - Hub and spacer material aluminium/laminas made of stainless steel

Size	Dimensions [mm]											Clamping screws DIN EN ISO 4017			Mass moment of inertia [kgm ²]	
	d _{max.}	D _H	l _{1, 2}	l ₃	L _{DK}	L _{DK1}	EDK	LEK	LEK1	d _h	s	M	z = number	T _A [Nm]	DK	EK
16	20	46	24	18	62	68	14	51	57	19.5	3	M5	4	6	0.000075	0.000063
21	28	58	28	22	75	81.2	19	59.5	65.7	24	3.5	M6	4	10	0.000218	0.000177
26	35	69	36	28	96	100.8	24	77	81.8	30	5	M5	8	6	0.000565	0.000467
36	42	84	43	35	109.6	118.3	23.6	90.8	99.5	48	4.8	M8	6	25	0.001581	0.001294
43	60	104	46	35	126	135.9	34	100	109.9	61	8	M8	6	25	0.004051	0.003250
51	70	124	50	38	138	150.5	38	108	120.5	73	8	M10	6	49	0.008981	0.007096
61	80	144	55	43	152	165.5	42	120	133.5	88	10	M12	6	85	0.024188	0.020678

Technical data

Size	T _{KN} ¹⁾ [Nm]	T _{K max} ¹⁾ [Nm]	Max. speed [rpm]	Torsion spring stiffness [Nm/rad]		Laminae type	Displacements of type DK			Displacements of type EK		
				Type EK	Type DK		Radial [mm]	Axial [mm]	Angular each laminae [degree]	Radial [mm]	Axial [mm]	Angular each laminae [degree]
				16	35		53	31,150	20,000	10,000	4 holes	0.19
21	70	105	24,700	40,000	20,000	4 holes	0.27	± 1.20	1.00	—	± 0.60	1
26	120	180	20,800	84,000	42,000	4 holes	0.33	± 1.60	1.00	—	± 0.80	1
36	340	510	17,100	280,000	140,000	6 holes	0.32	± 2.00	1.00	—	± 1.00	1
43	600	900	13,800	510,000	255,000	6 holes	0.45	± 2.20	1.00	—	± 1.10	1
51	1300	1950	11,600	920,000	460,000	6 holes	0.52	± 2.50	1.00	—	± 1.25	1
61	2000	3000	10,000	1,500,000	750,000	6 holes	0.56	± 2.60	1.00	—	± 1.30	1

¹⁾ For selection see page 22 et seqq.

Review of shaft-hub-connection: Friction torques T_R [Nm] for hub type 6.5

Size	Tolerance fit	Ø10	Ø12	Ø14	Ø15	Ø16	Ø19	Ø20	Ø24	Ø25	Ø28	Ø30	Ø32	Ø35	Ø38	Ø40	Ø42	Ø45	Ø48	Ø50	Ø55*	Ø60*	Ø65*	Ø70*	Ø75*	Ø80*
16	H7/h6	29	33	57	70	50	83	97																		
	H7/k6	34	42	64	76	62	96	109																		
21	H7/h6	27	45	75	91	79	125	145	127	144	201															
	H7/k6	36	56	83	99	93	139	157	169	187	245															
26	H7/h6				104	126	194	169	279	311	338	404	273	357												
	H7/k6				124	145	214	200	305	334	382	444	355	441												
36	H7/h6							241	395	438	521	616	523	664	647	741	841									
	H7/k6							284	430	471	558	646	640	779	778	875	974									
43	H7/h6										595	705	647	814	946	1073	980	1163	1360	1200	1072	1372				
	H7/k6										684	789	784	916	1096	1219	1144	1332	1534	1376	1370	1669				
51	H7/h6										750	818	1020	1085	1228	1166	1377	1605	1450	1607	2283	2255	2704			
	H7/k6										822	927	1117	1254	1392	1348	1568	1803	1652	1960	2387	2447	2842			
61	H7/h6													880	1074	1211	1264	1480	1597	1750	1911	2097	2542	2669	2718	3168
	H7/k6													951	1131	1258	1333	1534	1668	1810	2032	2239	2635	2785	2855	3252

* From Ø55 tolerance G7/m6

Ordering
example:

RADEX®-NC 26	DK	6.5 - Ø24		6.5 - Ø35	
Coupling size	Type	Hub type	Finish bore	Hub type	Finish bore

Hub type 6.5

Type DK

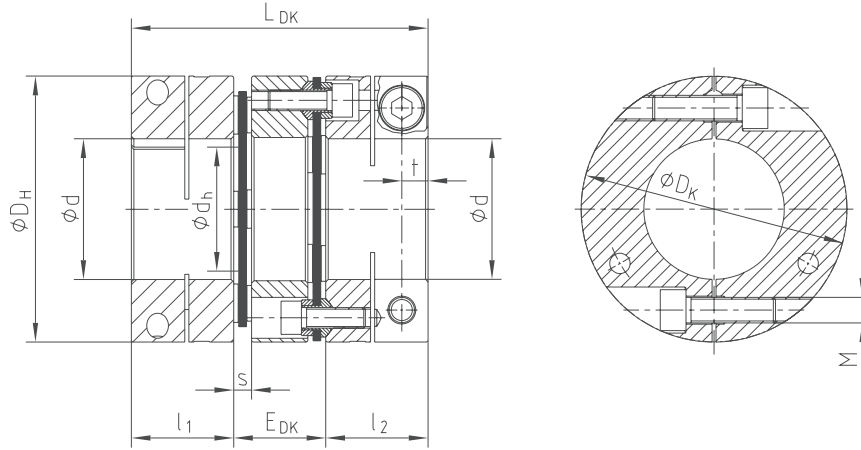

Type EK

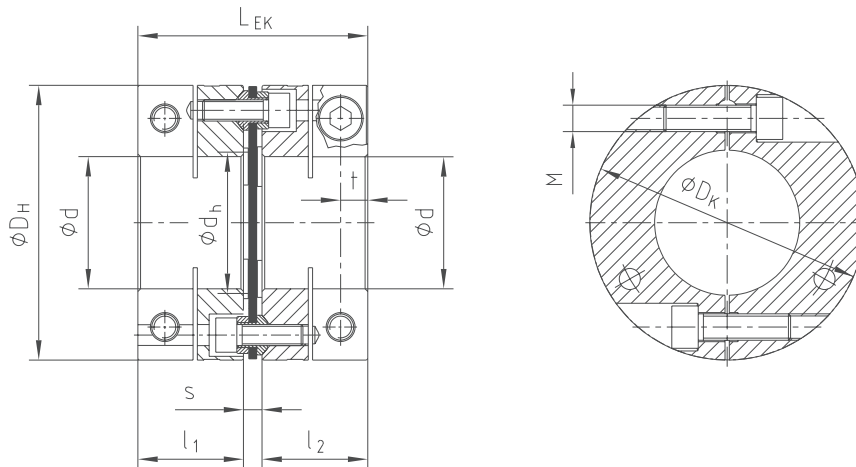

ROTEX® GS

TOOLFLEX®

RADEX®-NC

COUNTEX®

Backlash-free
servo couplings

Types of hubs



Type 6.5
Clamping ring hub