

Made for Motion

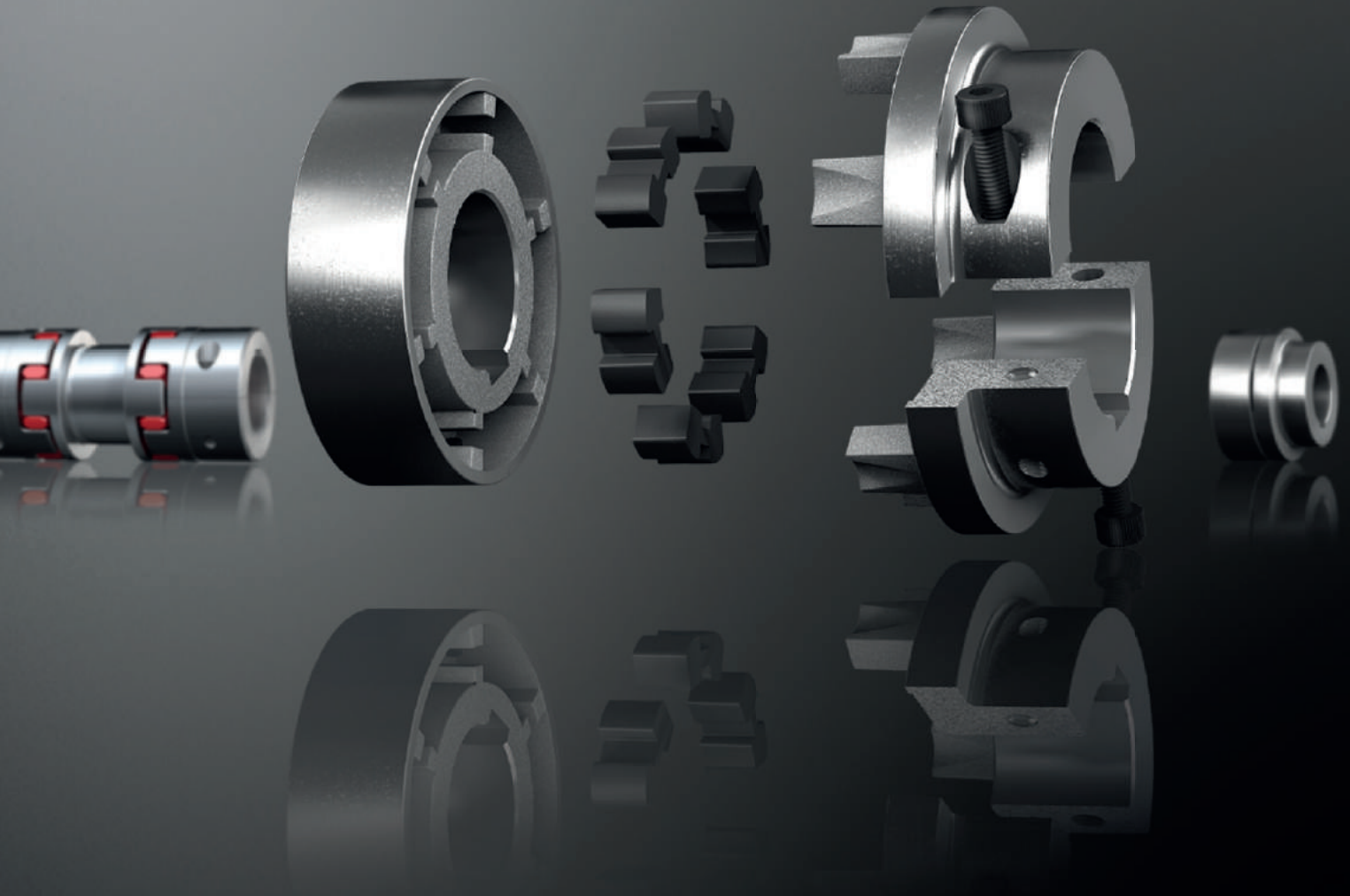

**ROFLEX®**

+ ROTEX® ZS-DKM-SH

**Flexible jaw coupling**

**ktr.com**

## Fast, easy and reliable - with the product finder and our online tools

The product finder allows you to get to the suitable product in just a few steps. For this purpose either make use of the search function if you already know the product or use the full-text search which guides you to the requested result via various product-specific filters. Our selection tools speed up the detailed product selection. Few tech-

nical data suffice to rapidly find the right product for your application in the configurators - without having to browse catalogues lengthily.



### Online tools

Tailor-made to your specifications - make use of our online tools



### Product finder

The suitable product for your application - fast and simple with our product finder.

# ROFLEX® N/ROFLEX® SH/ROTEX® ZS-DKM-SH Flexible jaw couplings

## Examples of application



**Pumps**

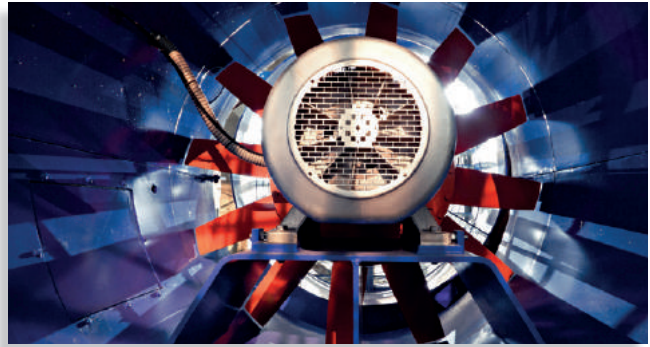

**Industrial fans**

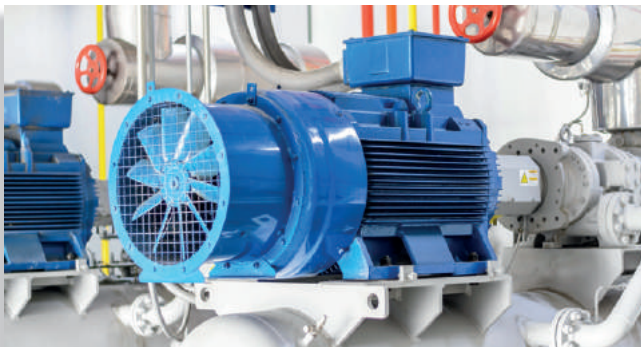

**Compactors and compressors**

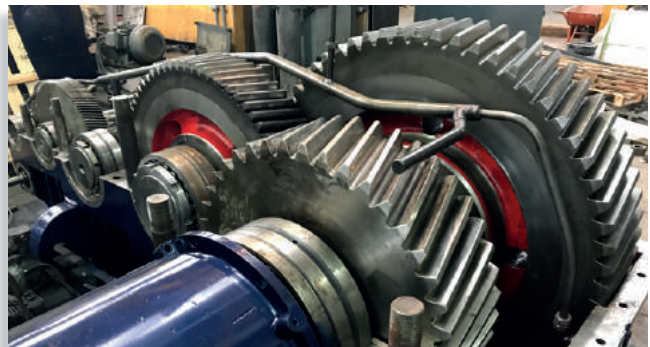

**Industrial gears**



**Conveyors**



**Agitators**

# COUPLING SELECTION ACCORDING TO DIN 740 PART II

## Coupling types



### Flexible jaw couplings

<p><b>ROTEX®</b></p> 	<p>Flexible coupling</p> <ul style="list-style-type: none"> <li>- Flexible</li> <li>- Maintenance-free</li> <li>- Fail-safe</li> <li>- Compact dimensions</li> <li>- Axial plug-in</li> </ul>
<p><b>ROTEX® ZS-DKM-SH</b></p> 	<p>Flexible coupling</p> <ul style="list-style-type: none"> <li>- Flexible</li> <li>- Maintenance-free</li> <li>- Fail-safe</li> <li>- Double-cardanic</li> <li>- Can be mounted radially</li> </ul>
<p><b>ROFLEX®</b></p> 	<p>Flexible coupling</p> <ul style="list-style-type: none"> <li>- Flexible</li> <li>- Maintenance-free</li> <li>- Fail-safe</li> <li>- Compact dimensions</li> <li>- Axial plug-in</li> </ul>
<p><b>POLY-NORM®</b></p> 	<p>Flexible coupling</p> <ul style="list-style-type: none"> <li>- Flexible</li> <li>- Maintenance-free</li> <li>- Fail-safe</li> <li>- Compact dimensions</li> <li>- Axial plug-in</li> </ul>
<p><b>POLY</b></p> 	<p>Flexible, shear type coupling</p> <ul style="list-style-type: none"> <li>- Flexible</li> <li>- Maintenance-free</li> <li>- Shear type</li> <li>- Axial plug-in</li> </ul>

### Gear couplings

<p><b>BoWex®</b></p> 	<p>Torsionally stiff curved-tooth gear coupling®</p> <ul style="list-style-type: none"> <li>- Torsionally stiff</li> <li>- Maintenance-free</li> <li>- Shear type</li> <li>- Compact dimensions</li> <li>- Single-cardanic or double-cardanic</li> <li>- Axial plug-in</li> </ul>
<p><b>BoWex® HEW Compact</b></p> 	<p>Highly flexible shaft coupling</p> <ul style="list-style-type: none"> <li>- Highly flexible</li> <li>- Maintenance-free</li> <li>- Shear type</li> <li>- Compact dimensions</li> <li>- Single-cardanic</li> <li>- Axial plug-in</li> </ul>

### Flange couplings for I. C.-engines

<p><b>BoWex-ELASTIC®</b></p> 	<p>Highly flexible flange coupling</p> <ul style="list-style-type: none"> <li>- Flexible to highly flexible</li> <li>- Maintenance-free</li> <li>- Shear type</li> <li>- Compact dimensions</li> <li>- Single-cardanic</li> <li>- Axial plug-in</li> </ul>
<p><b>MONOLASTIC®</b></p> 	<p>One-piece, flexible flange coupling</p> <ul style="list-style-type: none"> <li>- Flexible</li> <li>- Maintenance-free</li> <li>- Shear type</li> <li>- Compact dimensions</li> <li>- Single-cardanic</li> <li>- Axial plug-in</li> </ul>
<p><b>BoWex® FLE-PA/-PAC</b></p> 	<p>Torsionally stiff flange coupling</p> <ul style="list-style-type: none"> <li>- Torsionally stiff</li> <li>- Maintenance-free</li> <li>- Shear type</li> <li>- Compact dimensions</li> <li>- Single-cardanic</li> <li>- Axial plug-in</li> </ul>

# COUPLING SELECTION ACCORDING TO DIN 740 PART II

## Terminology of coupling selection

Description	Symbol	Definition or explanation
Rated torque of coupling [Nm]	$T_{KN}$	Torque that can be continuously transmitted over the entire permissible speed range
Maximum torque of coupling [Nm]	$T_{K\ max}$	Torque that can be transmitted as dynamic load $\geq 10^5$ times respectively $5 \cdot 10^4$ as vibratory load over the entire operating life of the coupling
Vibratory torque of coupling [Nm]	$T_{KW}$	Torque amplitude of the permissible periodical torque fluctuation with a frequency of 10 Hz and a basic load of $T_{KN}$ respectively dynamic load up to $T_{KN}$ .
Damping power of coupling [W]	$P_{KW}$	Permissible damping power with an ambient temperature of +30 °C
Rated torque of machine [Nm]	$T_N$	Stationary rated torque on the coupling
Rated torque of driving side [Nm]	$T_{AN}$	Rated torque of machine, calculated on the basis of rated power and rated speed
Rated torque of load side [Nm]	$T_{LN}$	Maximum figure of the load torque calculated on the basis of power and speed
Peak torque of machine [Nm]	$T_S$	Peak torque on the coupling
Peak torque of driving side [Nm]	$T_{AS}$	Peak torque with torque shock on driving side, e. g. tilting moment of the electric motor
Peak torque of load side [Nm]	$T_{LS}$	Peak torque with torque shock on load side, e. g. braking
Vibratory torque of machine [Nm]	$T_W$	Amplitude of the vibratory torque effective on the coupling

Description	Symbol	Definition or explanation
Damping power of machine [W]	$P_W$	Damping power which is effective on the coupling due to the load generated by the vibratory torque
Engine power [kW]	$P$	Rated power of drive
Speed [rpm]	$n$	Rated speed of engine
Rotational inertia coefficient of driving side	$M_A$	Factor considering the mass distribution with shocks and vibrations generated on the driving or load side
Rotational inertia coefficient of load side	$M_L$	
Mass moment of inertia of driving side [kgm <sup>2</sup> ]	$J_A$	Total of moments of inertia existing on the driving or load side referring to the coupling speed
Mass moment of inertia of load side [kgm <sup>2</sup> ]	$J_L$	
Mass moment of inertia of coupling [kgm <sup>2</sup> ]	$J_{KA}$	Mass mom. of inertia of the coupl. half on drive side
	$J_{KL}$	Mass mom. of inertia of the coupl. half on load side
Starting factor	$S_Z$	Factor considering the additional load caused by the starting frequency per hour
Shock factor on driving side	$S_A$	Factor considering the shocks arising depending on the application (e. g. starting shocks)
Shock factor on load side	$S_L$	
Temperature factor	$S_t$	Factor considering the lower loading capacity or larger deformation of an elastomer part under load particularly in case of increased temperatures
Operating factor	$S_B$	Factor considering the different demands on the coupling dependent on the application
Screw tightening torque [Nm]	$T_A$	Tightening torque of screw

Temperature factor $S_t$										
	-50 °C	-30 °C/+40 °C	≤ +50 °C	≤ +60 °C	≤ +70 °C	≤ +80 °C	≤ +90 °C	≤ +100 °C	≤ +110 °C	≤ +120 °C
<b>ROTEX®</b>										
T-PUR®	1.0	1.0	1.2	1.3	1.45	1.6	1.8	2.1	2.5	3.0
PUR	-	1.0	1.3	1.4	1.55	1.8	2.2	-	-	-
<b>ROFLEX®</b>										
NBR / PUR	-	1.0	1.0	1.0	1.4	1.8	-	-	-	-
<b>POLY-NORM®</b>										
NBR 78 Shore A	-	1.0	1.3	1.4	1.6	1.8	-	-	-	-
<b>POLY</b>										
NBR (cuboid)	-	1.0	1.3	1.4	1.6	1.8	-	-	-	-
<b>BoWex®</b>										
PA 6.6	1.0	1.0	1.0	1.0	1.2	1.4	1.6	1.8	-	-
PA-CF	1.0	1.0	1.0	1.0	1.1	1.2	1.4	1.6	1.9	2.2
BoWex® HEW Compact	-	1.0	1.0	1.0	1.1	1.4	1.7	-	-	-
<b>BoWex-ELASTIC®</b>										
Standard	-	1.0	1.0	1.0	1.1	1.4	1.7	-	-	-
<b>MONOLASTIC®</b>										
Standard	-	1.0	1.0	1.0	1.1	1.4	1.7	-	-	-
<b>BoWex® FLE-PA/-PAC</b>										
PA 6 GF	1.0	1.0	1.0	1.0	1.0	1.0	1.2	1.4	1.6	1.8
PA-CF	1.0	1.0	1.0	1.0	1.1	1.2	1.4	1.6	1.9	2.2

For the selection with PEEK spider a temperature factor is not necessary.  
For temperature factors for PA spiders see page 30.

Starting factor $S_Z$				
<b>ROTEX®, POLY-NORM®, POLY, BoWex®, BoWex® HEW Compact</b>				
Starting frequency per hour	< 100	< 200	< 400	< 800
$S_Z$	1.0	1.2	1.4	1.6
<b>BoWex-ELASTIC®</b>				
Starting frequency per hour	< 10	< 60	< 120	> 120
$S_Z$	1.0	1.5	2.0	On request

Shock factor $S_A/S_L$	
<b>ROTEX®, POLY-NORM®, POLY, BoWex®, BoWex® HEW Compact, BoWex-ELASTIC®</b>	
	$S_A/S_L$
Moderate shocks	1.5
Average shocks	1.8
Heavy shocks	2.5

Operating factor $S_B$	
<b>Hydrostatic drives for BoWex® FLE-PA, MONOLASTIC®</b>	
Applications	$S_B$
Wheel loaders	1.6
Compact loaders	1.6
Hydraulic excavators	1.4
Mobile cranes	1.6
Graders	1.5
Vibration rollers	1.4
Forklift trucks	1.6
Concrete mixer trucks	1.3
Concrete pumps	1.4
Asphalt finishers	1.4
Concrete cutters	1.4
Road milling machines	1.4

## Permissible load on feather keyway of the coupling hubs

The shaft-hub-connection needs to be inspected by the customer.

Permissible surface pressure according to DIN 6892 (method C)			
Cast iron (GJL)	225 N/mm <sup>2</sup>	Powder metal steel	180 N/mm <sup>2</sup>
Nodular iron (GJS)	225 N/mm <sup>2</sup>	Aluminium diecast (Al-D)	110 N/mm <sup>2</sup>
Steel	250 N/mm <sup>2</sup>	Aluminium wrought products (Al-H)	200 N/mm <sup>2</sup>
Polyamide	30 N/mm <sup>2</sup> (up to +40 °C)	For other steel materials $p_{perm}$ .	$0.9 \cdot R_e (R_{p0.2})$

# ROFLEX® N

## Flexible jaw couplings

### Two-part

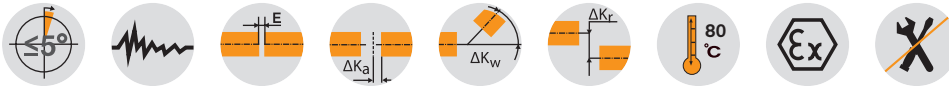
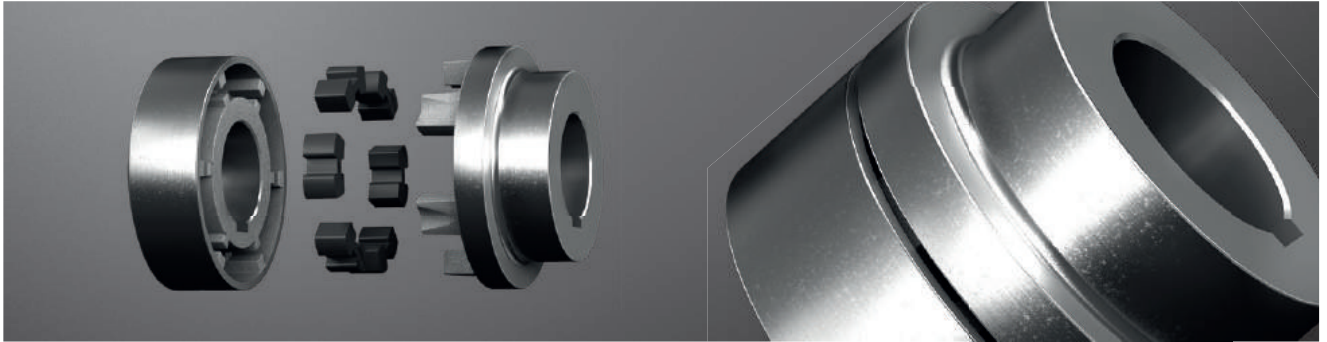

### Components

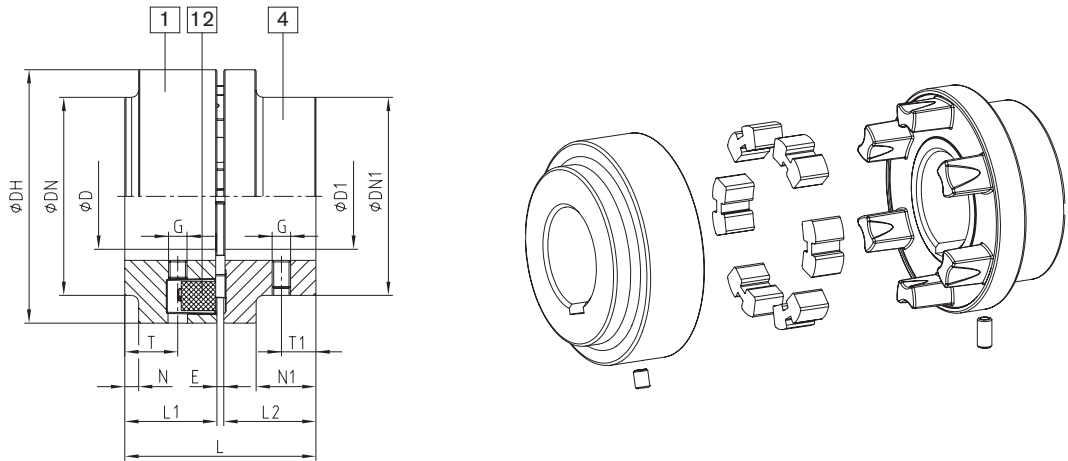

ROFLEX® type N																				
Size	Torque		Max. speed [rpm]	Dimensions														Mass moment of inertia J1 [kgm²]	Mass moment of inertia J4 [kgm²]	Total weight m [kg] <sup>1)</sup>
	TKN [Nm]	TKmax. [Nm]		Max. finish bore			General							Thread for setscrews						
				D	D1	L	L1, L2	E	DH	DN	DN1	N	N1	G	T	T1	TA [Nm]			
68	65	180	8500	28	38	43	20	3	68	-	-	-	-	M5	8.5	8	2	0.00016	0.00029	0.6
80	80	220	7500	35	45	63	30	3	80	-	68	-	20	M8	20.5	12	10	0.00059	0.00055	1.2
95	125	345	6800	45	48	73	35	3	95	76	76	5	23	M8	22	15	10	0.00116	0.00120	1.9
110	205	565	6500	50	55	83	40	3	110	86	86	6	26	M8	24	18	10	0.0024	0.0024	2.9
125	315	865	5800	60	65	103	50	3	125	100	100	14	32	M8	32	20	10	0.0046	0.0052	4.5
140	450	1240	5400	70	65	113	55	3	140	100	100	21	35	M10	13	22	17	0.0062	0.0077	5.3
160	790	2170	4800	75	70	124	60	4	160	108	108	21	40	M10	13	25	17	0.014	0.013	8.1
180	1150	3160	4350	85	80	144	70	4	180	125	125	28	50	M10	16	32	17	0.021	0.023	11.0
200	1800	4950	3950	90	90	164	80	4	200	140	140	33	56	M12	20	40	40	0.038	0.044	16.3
225	2100	5775	3600	100	100	184	90	4	225	150	150	38	72	M12	22	40	40	0.06	0.06	20.4
250	3550	9765	3000	110	110	205.5	100	5.5	250	165	165	40	82	M16	24	45	80	0.11	0.10	28.2
280	5000	13750	3000	120	120	225.5	110	5.5	280	180	180	45	90	M16	28	45	80	0.19	0.16	38.1

<sup>1)</sup> Mass moments of inertia J1 and J4 as well as the total weight m refer to the maximum bore diameters

■ = Available from stock

Ordering example:	ROFLEX® 110	Standard	ØD1 = 48	ØD4 = 38
	Coupling size	Type	Finish bore	Finish bore

# ROFLEX® SH

## Flexible jaw couplings

### Coupling with split hub

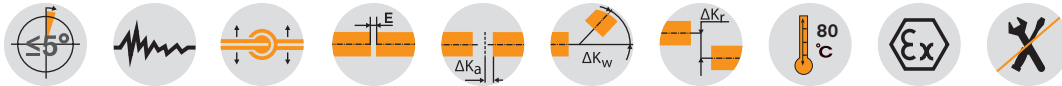
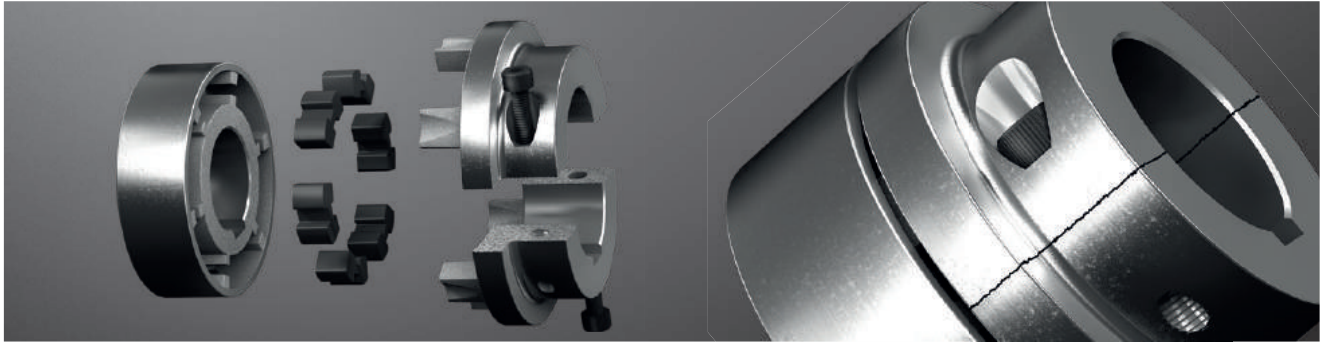

### Components

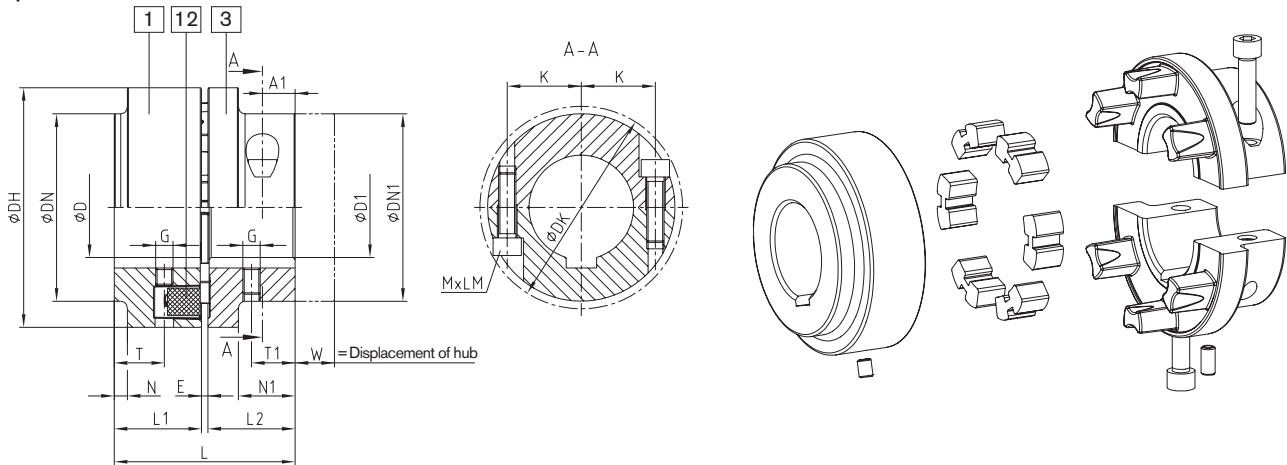

ROFLEX® type SH																												
Size	Torque		Max. speed [rpm]	Dimensions														Mass moment of inertia J1 [kgm²] <sup>1)</sup>	Mass moments of inertia J3 [kgm²] <sup>1)</sup>	Total weight m [kg] <sup>1)</sup>								
	T <sub>KN</sub> [Nm]	T <sub>Kmax.</sub> [Nm]		Max. finish bore							General										Thread for setscrews				Cap screws			
			D	D1	L	L1	L2	E	DH	DN	DN1	N	N1	W	G	T	T1	T <sub>A</sub> [Nm]	MxLM	DK	K	A1	A2	T <sub>A</sub> [Nm]				
80	80	220	7500	35	38	63	30	30	3	80	80	68	-	20	15.5	M8	20.5	12	10	M8x25	75	25	11	-	34	0.00059	0.00058	1.3
95	125	345	6800	45	42	73	35	35	3	95	76	76	5	23	18	M8	22	15	10	M8x30	82	28.5	13	-	34	0.00116	0.00123	2.0
110	205	565	6500	50	48	83	40	40	3	110	86	86	6	26	21	M8	24	18	10	M8x35	94	31.5	15	-	34	0.0024	0.0025	3.1
125	315	865	5800	60	55	103	50	50	3	125	100	100	14	32	23.5	M8	32	20	10	M10x40	108	38.5	20	-	67	0.0046	0.0052	4.5
140	450	1240	5400	70	60	113	55	55	3	140	100	100	21	35	25	M10	13	22	17	M10x35	108	39.0	10.5	25.5	67	0.0062	0.0080	5.7
160	790	2170	4800	75	65	124	60	60	4	160	108	108	21	40	30	M10	13	25	17	M12x35	118	42.5	12	29	115	0.014	0.014	8.5
180	1150	3160	4350	85	75	144	70	70	4	180	125	125	28	50	32	M10	16	32	17	M12x40	135	50	15	35	115	0.021	0.024	11.6
200	1800	4950	3950	90	85	164	80	80	4	200	140	140	33	56	34	M12	20	40	40	M16x50	153	54	17	40	290	0.038	0.044	17.8

<sup>1)</sup> Mass moments of inertia J1 and J4 as well as the total weight m refer to the maximum bore diameters  
■ = Available from stock

<b>Ordering example:</b>	ROFLEX® 110	SH	ØD1 = 42	ØD3 = 48
	Coupling size	Type	Finish bore	Finish bore

# ROTEX® ZS-DKM-SH

## Flexible jaw couplings

### Double-cardanic shaft coupling with SPLIT hubs

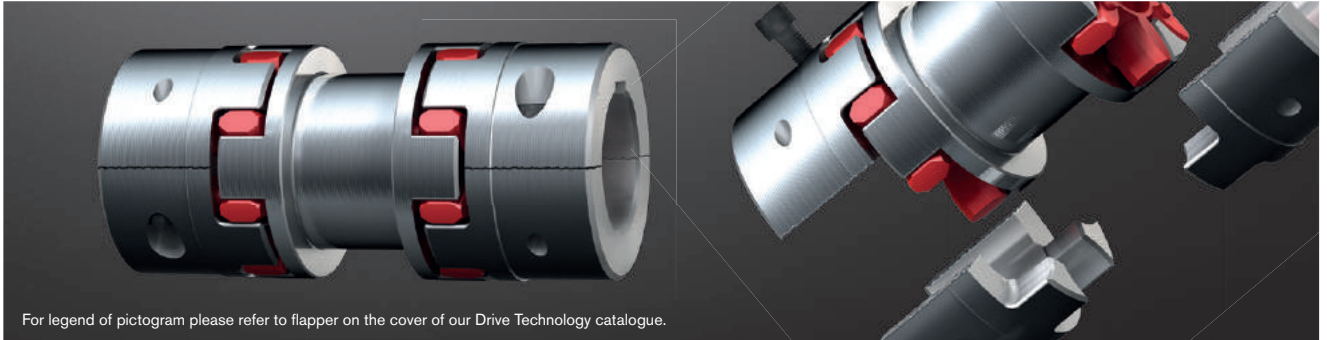

For legend of pictogram please refer to flapper on the cover of our Drive Technology catalogue.



ROTEX® type ZS-DKM-SH																							
Size <sup>3)</sup>	Drop-out center length DBSE [mm]	Finish bore D		Spider 98 Sh A GS T <sub>KN</sub> [Nm] <sup>1)2)</sup>	Dimensions [mm]											Screws DIN EN ISO 4762		Max. displacements					
		Min.	Max.		DH	DN1	DK	D1	L1, L2	L11	E	B1	S	LZS-DKM-SH	G	W	MxLM	T <sub>A</sub> [Nm]	Axial [mm]	with n = 1500 rpm		with n = 3000 rpm	
																				Radial [mm]	Angular [°]	Radial [mm]	Angular [°]
24	100	0	28	35	55	-	57.5	27	30	64	18	14	2.0	160	M5	12	M6x20	14	1.4	1.43		1.07	
	104									200				2.13						1.60			
28	100	0	38	95	65	-	73	30	35	60	20	15	2.5	170	M8	12	M8x25	34	1.5	1.40		1.05	
	100									210				2.10						1.57			
38	100	24	45	190	80	78	83.5	38	45	52	24	18	3.0	190	M8	15	M8x30	34	1.8	1.33		0.99	
	92									230				2.02						1.52			
42	100	24	55	265	95	94	97	46	50	48	26	20	3.0	200	M8	15	M10x35	67	2.0	1.29		0.97	
	88									240				2.00						1.49			
48	100	24	60	310	105	104	108.5	51	56	44	28	21	3.5	212	M8	15	M12x40	115	2.1	1.26		0.94	
	84									252				1.95						1.47			
55	100	24	70	410	120	118	122	60	65	40	30	22	4.0	230	M10	15	M12x45	115	2.2	1.22	1	0.92	0.75
	80									270				1.92						1.44			
	120									310				2.62						1.96			
	140									330				2.97						2.22			
65	140	24	80	625	135	135	132.5	68	75	70	35	26	4.5	290	M10	15	M12x40	115	2.6	1.83		1.37	
	110									330				2.53						1.90			
75	140	40	90	1280	160	160	158	80	85	60	40	30	5.0	310	M10	20	M16x50	290	3.0	1.75		1.31	
	100									350				2.44						1.83			
	120									370				2.79						2.09			
	170									420				3.67						2.75			
90	180	40	110	2400	200	200	197	100	100	90	45	34	5.5	380	M12	20	M20x60	560	3.4	2.36		1.76	
	160									450				3.58						2.68			

<sup>1)</sup> Maximum torque of the coupling TK max = rated torque of the coupling TK rated x 2.

<sup>2)</sup> Mathematically transmittable torque with double-cardanic types acc. to 92 Sh-A GS using the higher quality spiders 98 Sh-A GS

<sup>3)</sup> ROTEX-SPLIT hub material sizes 24 and 28 = sintered steel; hub material sizes 38 to 90 = EN-GJL

<sup>4)</sup> Hub type 7.1 = SPLIT hub with feather keyway and thread for setscrews

Ordering example:	ROTEX® 38	ZS-DKM-SH	140	98 ShA-GS	7.1 <sup>4)</sup>	Ø 38	7.1 <sup>4)</sup>	Ø30
	Coupling size	Type	Shaft distance dimension DBSE	Spider hardness	Hub type	Finish bore	Hub type	Finish bore



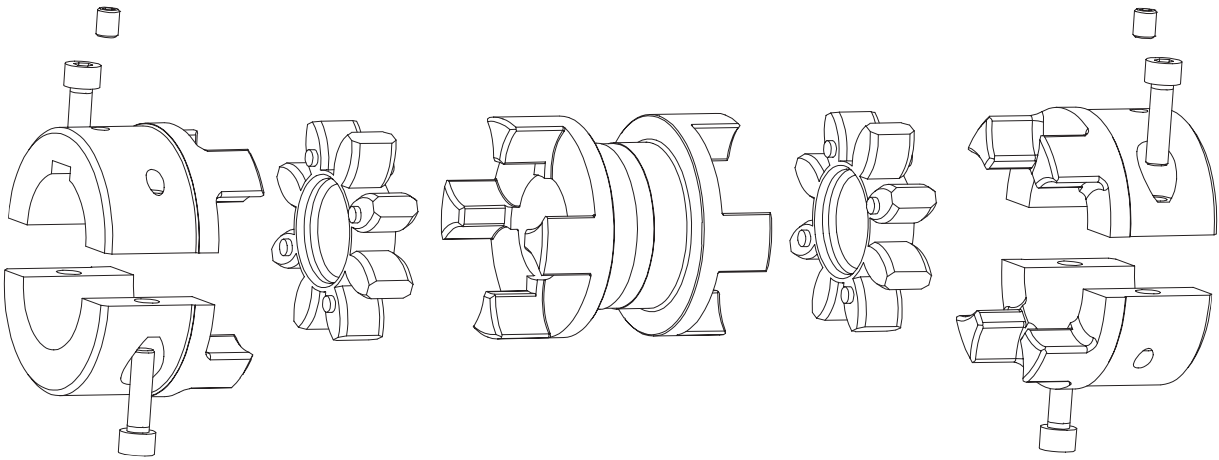
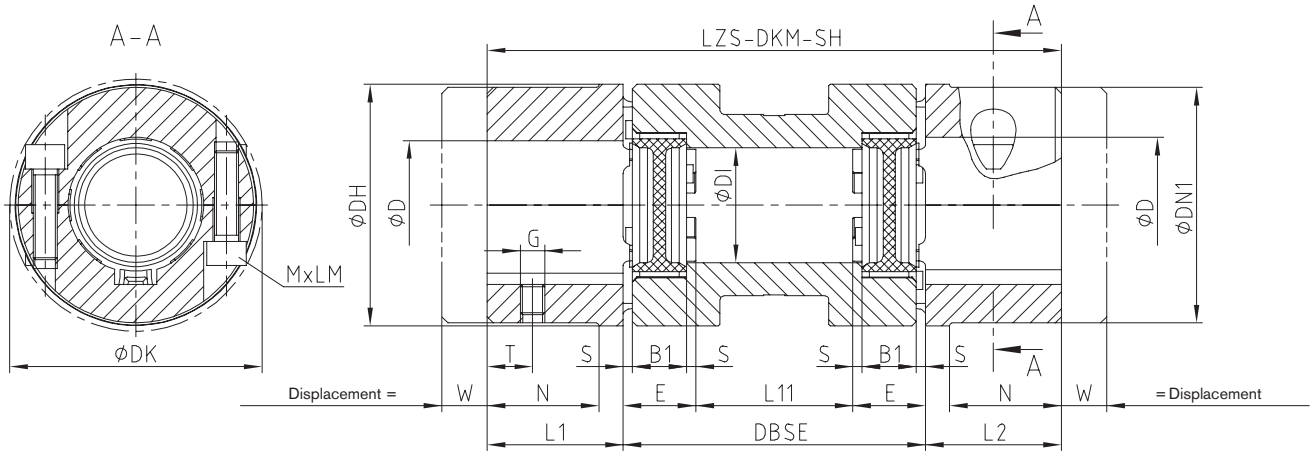

# KTR Germany:

## Headquarters:

**KTR Systems GmbH**  
Carl-Zeiss-Straße 25  
D-48432 Rheine  
Phone: +49 5971 798-0  
Fax: +49 5971 798-698 or 798-450  
E-mail: mail@ktr.com  
Internet: www.ktr.com

## KTR Brake Systems GmbH

Competence Center for Brake Systems  
Zur Brinke 14  
D-33758 Schloß Holte-Stukenbrock  
Phone: +49 5207 99161-0  
Mobile: +49 175 2650033  
Fax: +49 5207 99161-11

## Leiter Vertrieb Bremsen Wind

Jörn Edzards, Dipl.-Ing. (FH)  
Zur Brinke 14  
D-33758 Schloß Holte-Stukenbrock  
Phone: +49 5207 99161-0  
Mobile: +49 175 2650033  
E-mail: j.edzards@ktr.com

## Leiter Vertrieb Bremsen Industrie

Thomas Wienkotte, Dipl.-Ing. (FH)  
Am Rott 18  
D-50171 Kerpen  
Phone: +49 2237 971796  
Mobile: +49 172 5859448  
E-mail: t.wienkotte@ktr.com

## KTR Thinktank

Walder Strasse 53  
40724 Hilden  
Germany  
Phone: +49 5971 798-885 / 886  
E-mail: thinktank@ktr.com

## Außendienst Norddeutschland für Hydraulik-Komponenten

Gunnar Ehlers  
Finkenstieg 4b  
21629 Neu Wulmstorf  
Mobile: +49 174 3301536  
E-mail: g.ehlers@ktr.com

## Außendienst Bayern, Baden-Württemberg und Österreich für Hydraulik-Komponenten

Klaus-Peter Sprödhuber  
Hussengutstr. 55  
95445 Bayreuth  
Phone: +49 921 16388991  
Mobile: +49 172 1096496  
E-mail: k.sproedhuber@ktr.com

## Schleswig-Holstein, Nord-Niedersachsen, Hamburg, Bremen

Martin Lau, Maschinenbautechniker  
KTR Ingenieurbüro Hamburg  
Geschwister-Scholl-Allee 44  
25524 Itzehoe  
Phone: +49 4821 4050812  
Mobile: +49 172 5310014  
E-mail: m.lau@ktr.com

## NRW: Großraum Düsseldorf, Köln, Aachen

John Wein,  
B. Sc. Wirtschaftsingenieurwesen  
KTR Ingenieurbüro Hilden  
Walder Str. 53  
40724 Hilden  
Mobile: +49 151 62489605  
E-mail: j.wein@ktr.com

## Emsland, Mitte- und Süd-Niedersachsen, Ostwestfalen

Rainer Lüttmann  
KTR Systems GmbH  
Carl-Zeiss-Straße 25  
48432 Rheine  
Phone: +49 5971 798-340  
Mobile: +49 172 5322164  
E-mail: r.luettmann@ktr.com

## Siegerland

René Szabo, Maschinenbautechniker  
Waldstr. 67  
57080 Siegen-Niederschelden  
Phone: +49 5971 798 7777  
Mobile: +49 175 81 64 844  
E-mail: r.szabo@ktr.com

## Ruhrgebiet, Hessen-Nord

René Pottmann, Maschinenbautechniker  
KTR Ingenieurbüro Dortmund  
Lindemannstraße 9  
44137 Dortmund  
Phone: +49 231 91259060  
Mobile: +49 162 2186045  
E-mail: r.pottmann@ktr.com

## Hessen, Rheinland-Pfalz, Saarland

Martin Dietrich, Ingenieur Maschinenbau  
KTR Ingenieurbüro Frankfurt  
Schorbachstr. 9  
35510 Butzbach  
Phone: +49 6033 9248494  
Mobile: +49 172 5329968  
E-mail: m.dietrich@ktr.com

## Berlin, Mecklenburg-Vorpommern Südost, Sachsen-Anhalt, Brandenburg

Thüringen Nord, Sachsen  
Norman Schlag, Tech. BW (IHK)  
KTR Ingenieurbüro Leipzig  
Hauptstraße 101  
04416 Markkleeberg  
Phone: +49 341 35416467  
Mobile: +49 173 4716266  
E-mail: n.schlag@ktr.com

## Baden-Württemberg Nord

Eberhard Maier, Dipl.-Ing. (FH)  
Hortensienweg 1  
70374 Stuttgart, Sommerain  
Phone: +49 71 16 5842957  
Mobile: +49 172 5355056  
E-mail: e.maier@ktr.com

## Baden-Württemberg Süd

Jochen Glöckler, Maschinenbautechniker  
KTR Ingenieurbüro Balingen  
Hölzlestraße 44  
72336 Balingen  
Phone: +49 7433 91381  
Mobile: +49 172 5310049  
E-mail: j.gloeckler@ktr.com

## Bayern-Nord, Thüringen Süd

Alexander Ennulat, Dipl.-Ing.  
KTR Ingenieurbüro Römerstein  
Grabenstetter Str. 28  
72587 Römerstein  
Phone: +49 7382 9369226  
Mobile: +49 162 4160354  
E-mail: a.ennulat@ktr.com

## Bayern-Süd, Baden-Württemberg Ost

Peter Benkard, Dipl.-Ing. (FH)  
KTR Ingenieurbüro Adelsried  
Am Mittelfeld 13  
86477 Adelsried  
Phone: +49 8293 9605-04  
Mobile: +49 172 5313059  
E-mail: p.benkard@ktr.com

For all representatives and sales partners please refer to [www.ktr.com](http://www.ktr.com).

# KTR worldwide:

## Algeria

KTR Algérie  
Algeria Business Center -  
Pins Maritimes  
DZ-16130 Alger Mohammadia  
Phone: +213 661 92 24 00  
E-mail: ktr-dz@ktr.com

## Brazil

KTR do Brasil Ltda.  
Rua Jandaia do Sul 471 -  
Bairro Emiliano Perneta  
Pinhais - PR - Cep: 83324-040  
Phone: +55 41 36 69 57 13  
E-mail: ktr-br@ktr.com

## Chile

KTR Systems Chile SpA  
Calle Bucarest 17  
Oficina 33 Providencia  
Santiago de Chile  
Phone: +56 23 22 46 674  
Mobile: +56 9 44 75 57 02  
E-mail: ktr-cl@ktr.com

## China

KTR Power Transmission Technology  
(Shanghai) Co. Ltd.  
Building 1005, ZOBON Business Park  
999 Wangqiao Road  
Pudong  
Shanghai 201201  
Phone: +86 21 58 38 18 00  
Fax: +86 21 58 38 19 00  
E-mail: ktr-cn@ktr.com

## Czech Republic

KTR CR, spol. s r.o.  
Brněnská 559  
569 43 Jevíčko  
Czech Republic  
Phone: +420 461 325 014  
E-mail: ktr-cz@ktr.com

## Denmark

KTR Systems Danmark ApS  
Vejlsovej 51, Bygning N  
8600 Silkeborg  
Phone: +45 39 39 10 50  
E-mail: ktr-dk@ktr.com

## Finland

KTR Finland OY  
Tiistiniityntie 4  
SF-02230 Espoo  
Phone: +358 2 07 41 46 10  
Fax: +358 2 07 41 46 19  
E-mail: ktr-fi@ktr.com

## France

KTR France SAS  
5 Chemin de la Brocardière  
CS 71359  
F-69573 DARDILLY CEDEX  
Phone: +33 4 78 64 55 26  
Fax: +33 4 78 64 54 31  
E-mail: ktr-fr@ktr.com

## India

KTR Couplings (India) Pvt. Ltd.,  
T-36 / 37 / 38, MIDC Bhosari  
Pune 411026  
Phone: +91 20 27 12 73 24  
Fax: +91 20 27 12 73 23  
E-mail: ktr-in@ktr.com

## Italy

KTR Systems GmbH  
Sede Secondaria Italia  
Via Giovanni Brodolini, 8  
I - 40133 Bologna (BO)  
Phone: +39 051 613 32 32  
Fax: +39 051 298 55 77  
E-mail: ktr-it@ktr.com

## Japan

KTR Japan Co., Ltd.  
Toei Bldg.2F, 6-1-8 Motomachi-dori  
Chuo-ku, Kobe  
650-0022 Japan  
Phone: +81 7 89 54 65 70  
Fax: +81 7 89 54 65 75  
E-mail: ktr-jp@ktr.com

## Korea

KTR Korea Ltd.  
#604, Songwon bldg., 89-10, Gal-  
maejungang-ro, Guri-si, Gyeonggi-do,  
11901 Korea  
Phone: +82 3 15 69 45 10  
Fax: +82 3 15 69 45 25  
E-mail: ktr-kr@ktr.com

## Netherlands

KTR Benelux B. V.  
Postbus 87  
Oosterveldsingel 3  
NL-7558 PJ Hengelo (O)  
Phone: +31 74 2553680  
Fax: +31 74 2553689  
E-mail: ktr-nl@ktr.com

## Norway

KTR Systems Norge AS  
Lahaugmoveien 81  
N-2013 Skjetten  
Phone: +47 64 83 54 90  
Fax: +47 64 83 54 95  
E-mail: ktr-no@ktr.com

## Poland

KTR Polska Sp. z o.o.  
ul. Czerwone Maki 65  
PL-30-392 Kraków  
Phone: +48 12 267 28 83  
Fax: +48 12 267 07 66  
E-mail: ktr-pl@ktr.com

## Russia

KTR RUS LLC  
6 Verhnii Pereulok 12  
Litera A, Office 229  
194292 St. Petersburg  
Phone: +7 812 383 51 20  
Fax: +7 812 383 51 25  
E-mail: ktr-ru@ktr.com  
Internet: www.ktr.ru

## South Africa

KTR Couplings SA (Pty) Ltd.  
28 Spartan Road, Kempton Park,  
Spartan Ext. 21  
Phone: +27 11 281 3801  
Fax: +27 11 281 3812  
E-mail: ktr-za@ktr.com

## Spain

KTR Systems GmbH  
Estartetxe, n° 5-Oficina 322  
E-48940 Leioa (Vizcaya)  
Phone: +34 9 44 80 39 09  
Fax: +34 9 44 31 68 07  
E-mail: ktr-es@ktr.com

## Sweden

KTR Sverige AB  
Box 7010  
S-187 11 Täby  
Phone: +46 86 25 02 90  
E-mail: info.se@ktr.com

## Switzerland

KTR Systems Schweiz AG  
Bahnstr. 60  
CH-8105 Regensdorf  
Phone: +41 4 33 11 15 48  
Fax: +41 4 33 11 15 56  
E-mail: ktr-ch@ktr.com

## Taiwan

KTR Taiwan Ltd.  
No.: 30-1, 36 Rd  
Taichung Industry Zone  
Taichung City  
407 Taiwan (R. O. C.)  
Phone: +886 4 23 59 32 78  
Fax: +886 4 23 59 75 78  
E-mail: ktr-tw@ktr.com

## Turkey

KTR Turkey  
Güç Aktarma Sistemleri San. ve Tic. Ltd.  
Şti.  
Kayışdağı Cad. No: 117/2  
34758 Atasehir -Istanbul  
Phone: +90 216 574 37 80  
Fax: +90 216 574 34 45  
E-mail: ktr-tr@ktr.com

## United Kingdom

KTR U.K. Ltd.  
Robert House  
Unit 7, Acorn Business Park  
Woodseats Close  
Sheffield  
United Kingdom, S8 0TB  
Phone: +44 11 42 58 77 57  
Fax: +44 11 42 58 77 40  
E-mail: ktr-uk@ktr.com

## USA

KTR Corporation  
122 Anchor Road  
Michigan City, Indiana 46360  
Phone: +1 219 8 72 91 00  
Fax: +1 219 8 72 91 50  
E-mail: ktr-us@ktr.com

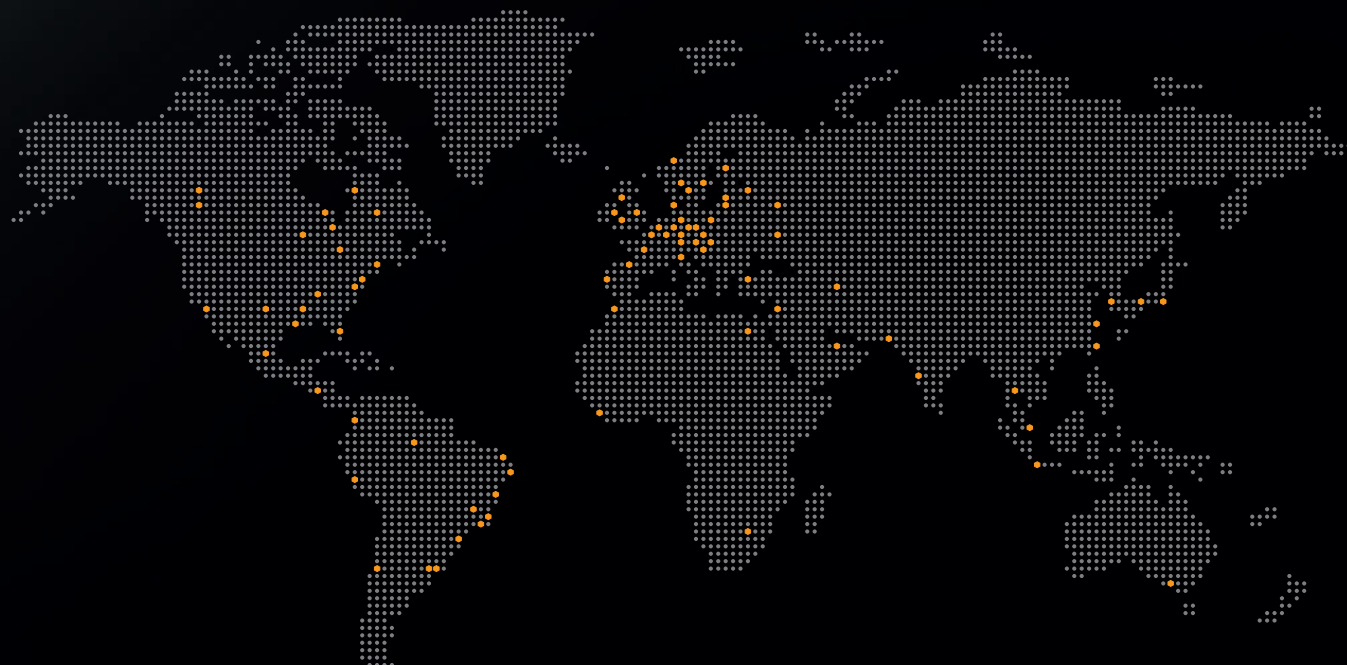



**Headquarters**

**KTR Systems GmbH**

Carl-Zeiss-Straße 25

D-48432 Rheine

Phone: +49 5971 798-0

Fax: +49 5971 798-698 or 798-450

E-mail: [mail@ktr.com](mailto:mail@ktr.com)

Internet: [www.ktr.com](http://www.ktr.com)

Made for Motion 

The KTR logo is a stylized orange graphic consisting of a hexagonal shape with a pointed top and bottom, and the letters "KTR" in a bold, sans-serif font inside the hexagon.

# Certificates and Approvals

Being one of the first companies in the field of drive technology, KTR was certified in accordance with DIN EN ISO 9001 already in 1993, including the plants in Poland, China, India and USA.

Currently KTR products have been approved by numerous internationally renowned societies for standardization and classification. Individual approvals by other societies can be implemented on request without fail.



Original approval date:

17.05.2011

Date of the audit:

08.06.2011

Date of next recertification:

Valid until:

17.06.2008

Bureau Veritas Certification certifies that the Management System of the above organisation has been assessed and found to be in accordance with the requirements of the standards detailed below.

Standard

DIN EN ISO 9001:2008

DIN EN ISO 14001:2009

Scope of supply



# Legend of pictograms

	torsionally rigid		Light-weight		Maintenance-free
	Torsionally flexible		Axial compensation		Protected against corrosion
	Highly flexible		Angular compensation		Electrically insulating
	Damping vibrations		Radial compensation		Maximum speed $n_{max}$ <b>X.000</b> rpm
	Axial plug-in		Shiftable at standstill		No eddy current losses
	Consider shaft distance		Double-cardanic		Torque limiter slipping
	Relatively short shaft distance		Radial disassembly, ease of service		Torque limiter with synchronous ratching
	Maximum operating temperature		Standard drop-out center length		Torque limiter with idle rotation type
	High speeds		API Available in accordance with API		Hardened surface
	Backlash-free		Complying with ATEX For details refer to our ATEX leaflet		Accuracy X %
	Shear type, separating, slipping		ABS Certified in accordance with ABS		Consider axial displacement
					Additional features compared to standard version