

RUFLEX®

Torque limiters

Structure and operation

- Load-retaining overload protection up to 12.000 Nm (standard)
- Available with various drive components (e. g. sprocket) and combinations (e. g. ROTEX®)
- Asbestos-free and rust-proof friction lining for dry running (ATEX available on request (Ex))
- High wear capacity, long service life
- High-quality slide bush with dry lubricant
- Torque setting while in place



- Protection of the nut by locking in 12 different positions
- Easy assembly and torque setting
- Coupling components made of steel, large safety reserves
- Corrosion protection by zinc-coated and passivated surfaces
- Rust-proof and acid-proof type on request
- High power density due to high-quality disk springs and friction linings

The RUFLEX® modular system provides solutions for your drive, too.

The combination with the proven KTR couplings and the integration of customised drive components (e. g. sprockets) allows for an overload protection optimally adapted to the respective application.

Various disk spring layerings and high-quality friction linings ensure a high power density even with only small mounting space.

RUFLEX® consists of the following components:

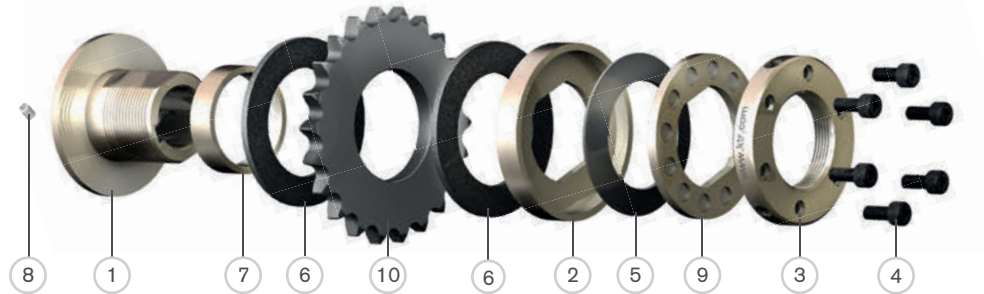

List of components:

- | | |
|-------------------------|------------------------------------|
| ① Hub | ⑥ Friction lining |
| ② Pressure ring | ⑦ Slide bush |
| ③ Setting nut | ⑧ Setscrew |
| ④ Torque setting screws | ⑨ Lock washer |
| ⑤ Disk spring | ⑩ Drive component (e. g. sprocket) |

Disk spring layerings:



- 1TF**
- Small specific load on friction linings
 - For small to average torques
 - Long service life of friction linings



- 1TFD**
- Small specific load on friction linings
 - Torques like with type 1TF
 - Only small decrease of torque even with a longer period of friction
 - Precision torque adjustment due to double spring excursion



- 2TF**
- Average specific load on friction linings
 - Average wear and decrease of torque with longer slipping periods
 - Double torque due to double disk spring layering



- 2TFD**
- Average specific load on friction linings
 - Torques like with type 2TF
 - Only small decrease of torque even with a longer period of friction
 - Precision torque adjustment due to double spring excursion



- 3TF**
- High specific load on friction linings
 - High wear and decrease of torque with longer slipping periods
 - Suitable only in special cases for designs with only limited dimensions

RUFLEX® Torque limiters

Standard width of drive component

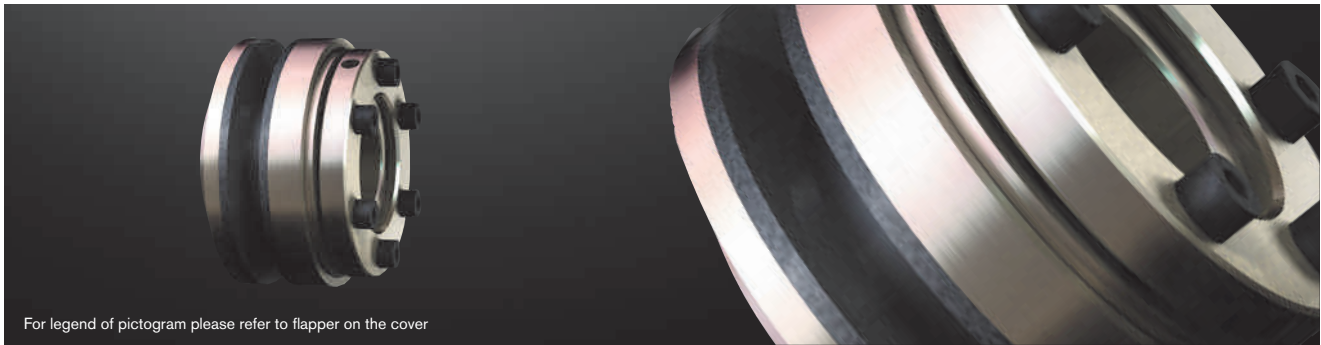

For legend of pictogram please refer to flapper on the cover

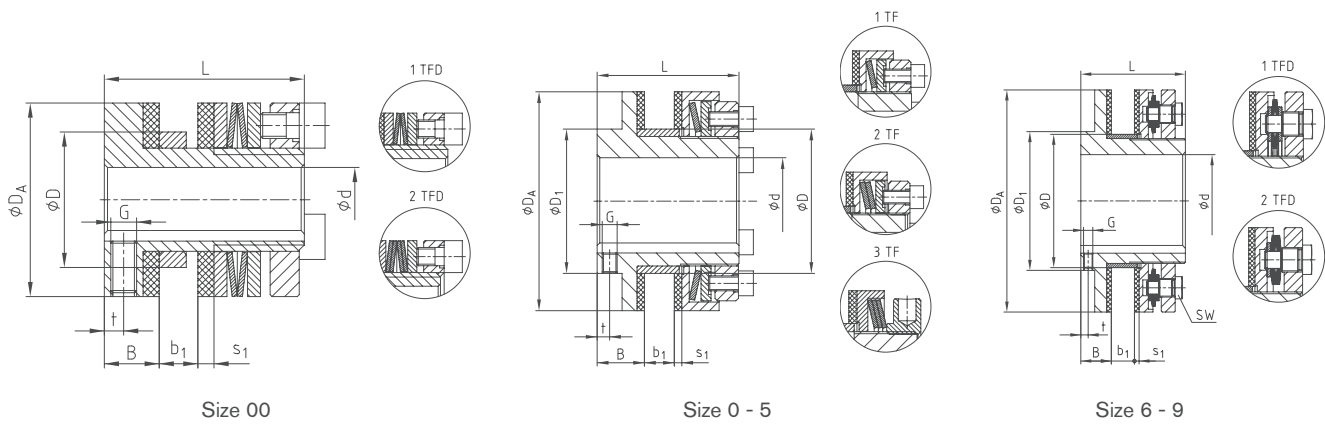

Technical data – dimensions

Size	Max. speed ⁴⁾ [rpm]	Torques [Nm]			Dimensions [mm]											
					Bore d		D ²⁾	D ₁	D _A	B	Drive component		s ₁	L	Setscrew	
		Pilot bore	Max.	Min.	Max.	t					G					
00	10000	(0.5) ⁵⁾ 1-3	2-5	–	–	10	21	–	30	8.5	2	6	2.5	31	3	M4
0	8500	2-10	4-20	–	–	19 (20) ¹⁾	35	45	45	8.5	2	6	2.5	33	3	M4
01	6600	5-35	10-70	–	–	22	40	40	58	16	3	8	3	45	4	M5
1	5600	20-75	40-150	130-200	–	25	44	45	68	17	3	10	3	52	5	M5
2	4300	25-140	50-280	250-400	–	35	58	58	88	19	4	12	3	57	5	M6
3	3300	50-300	100-600	550-800	–	45	72	75	115	21	5	15	4	68	5	M6
4	2700	90-600	180-1200	1100-1600	–	55	85	90	140	23	6	18	4	78	5	M8
5	2200	400-800	800-1600	1400-2100	–	65	98	102	170	29	8	20	5	92	8	M8
6	1900	300-1200	600-2400	–	38	80	116	120	200	31	8	23	5	102	8	M8
7	1600	600-2200	1200-4400	–	45	100	144	150	240	33	8	25	5	113	8	M10
8	1300	900-3400	1800-6800	–	58	120	170	180	285	35	8	25	5	115	8	M10
9	1000	2500-6000	6000-12000	–	65	140	237	225	350	53	16	28	6	162	11	M12

¹⁾ The figure in brackets specifies the max. bore with keyway to DIN 6885 sheet 3 (low-rise design)

²⁾ Bore tolerance (drive component): F8 with size 00 - 4, H8 with size 5 - 9

³⁾ With clamping setting nut to be used on types limited in dimensions only

⁴⁾ See comments on page 249

⁵⁾ With special disk spring

On request:

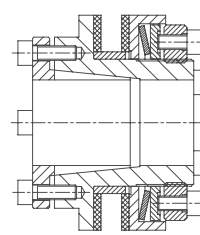
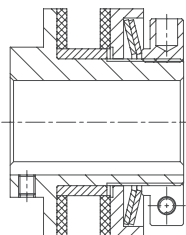

- With clamping setting nut for size 0 - 5 (standard with 3TF)
- For radial torque setting

- With taper bush (hub type 4.5)
- Frictionally engaged shaft-hub-connection

Ordering example:	RUFLEX® 1	2TF	b ₁ 10	d Ø20
	Type/size	Disk spring layering	Width of drive component b ₁	Finish bore

RUFLEX® Torque limiters

With sprocket



For legend of pictogram please refer to flapper on the cover

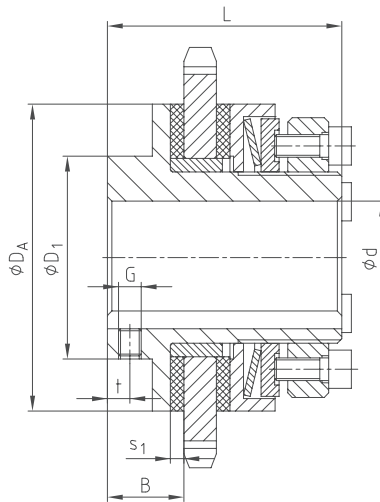

Technical data – dimensions

Size ⁴⁾	Max. speed ³⁾ [rpm]	Torques [Nm]			Dimensions [mm]								
					Max. bore d	D ₁	D _A	B	s ₁	L	Setscrew		Standard sprocket ²⁾
		t	G										
01	6600	5-35	10-70	–	22	40	58	16	3	45	4	M5	06 B-1 (² / ₈ x ⁷ / ₃₂) z = 23
1	5600	20-75	40-150	130-200	25	45	68	17	3	52	5	M5	08 B-1 (¹ / ₂ x ⁵ / ₁₆) z = 22
2	4300	25-140	50-280	250-400	35	58	88	19	3	57	5	M6	08 B-1 (¹ / ₂ x ⁵ / ₁₆) z = 27
3	3300	50-300	100-600	550-800	45	75	115	21	4	68	5	M6	12 B-1 (³ / ₄ x ⁷ / ₁₆) z = 22
4	2700	90-600	180-1200	1100-1600	55	90	140	23	4	78	5	M8	16 B-1 (1 x 17.02) z = 21

¹⁾ With clamping setting nut to be used on types limited in dimensions only

²⁾ Review minimum number of teeth required / Other sprockets available on request.

³⁾ See comments on page 249

⁴⁾ Other sizes on request

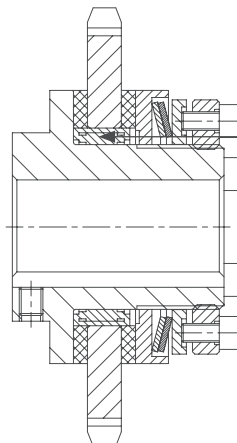

Special type:

- If requested, available with needle bearing instead of slide bush
- For high radial load on the sprocket
- For high speeds or long slipping periods

Ordering example:

RUFLEX® 1	2TF	d Ø20	08 B -1 (¹ / ₂ x ⁵ / ₁₆), z = 29	100 Nm
Type/size	Disk spring layering	Finish bore	Sprocket	Torque set

RUFLEX® Torque limiters

Max. type

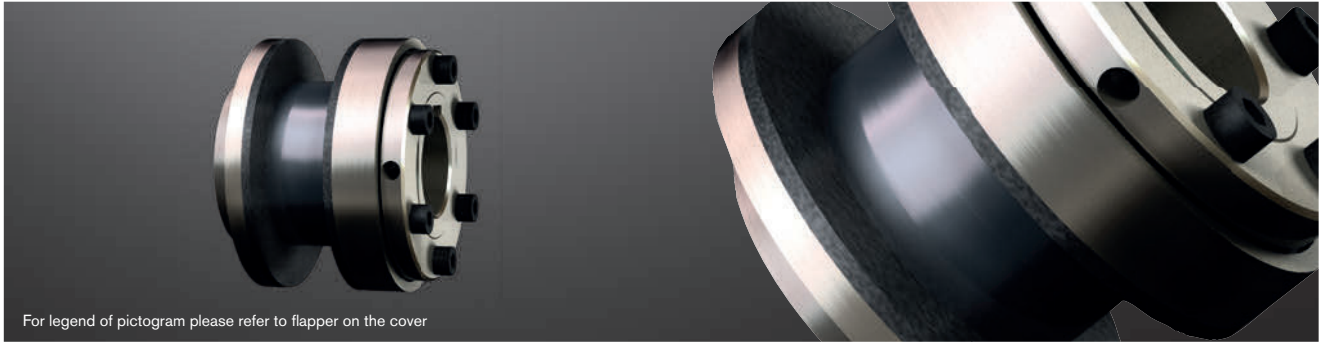

For legend of pictogram please refer to flapper on the cover

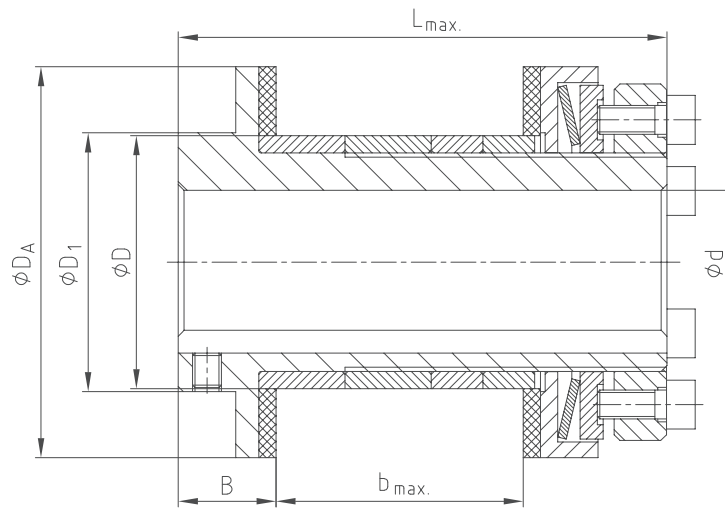

Technical data – dimensions

Size	Max. speed ³⁾ [rpm]	Torques [Nm]			Dimensions [mm]						
		1TF	2TF	3TF ²⁾	Max. bore d	D ₁	D _A	B	Max. b	D ¹⁾	Max. L
01	6600	5-35	10-70	–	22	40	58	16	33	40	70
1	5600	20-75	40-150	130-200	25	45	68	17	43	44	85
2	4300	25-140	50-280	250-400	35	58	88	19	54	58	100
3	3300	50-300	100-600	550-800	45	75	115	21	62	72	115
4	2700	90-600	180-1200	1100-1600	55	90	140	23	91.5	85	154

¹⁾ Bore tolerance (drive component): F8

²⁾ With clamping setting nut to be used on types limited in dimensions only

³⁾ See comments on page 249

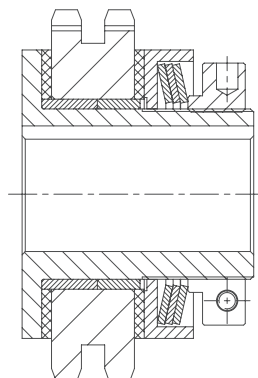

Example:

- RUFLEX® max. with sprocket assembled
- Available as a complete subassembly with torque preset

Ordering example:

RUFLEX® max. 1	2TF	b 35	d Ø20
Type/size	Disk spring layering	Width of drive component b	Finish bore

RUFLEX® Torque limiters

With torsionally flexible ROTEX®



For legend of pictogram please refer to flapper on the cover

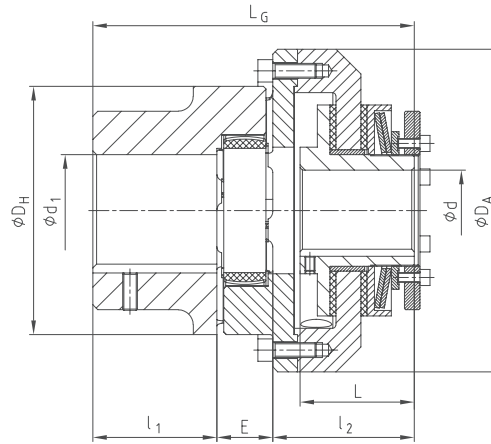

Technical data – dimensions																
RUFLEX® size	ROTEX® size	RUFLEX® Torques [Nm]			ROTEX® ³⁾ Torques [Nm]		Dimensions [mm]									
		1TF	2TF	3TF ²⁾	T _{KN}	T _{K max}	Bore d		Max. bore	D _H	D _A	l ₁	l ₂	E	L	L _G
Pilot bore	Max.	d ₁														
00	14	(0.5) ⁴⁾ 1-3	2-5	–	12.5	25	–	10	16	30	44	11	35	13	31	59.5
0	19	2-10	4-20	–	17	34	–	19 (20) ¹⁾	25	40	63	25	37	16	33	78
01	24	5-35	10-70	–	60	120	–	22	35	55	80	30	50	18	45	98
1	28	20-75	40-150	130-200	160	320	–	25	40	65	98	35	58	20	52	113
2	38	25-140	50-280	250-400	325	650	–	35	48	80	120	45	64	24	57	133
3	48	50-300	100-600	550-800	525	1050	–	45	62	105	162	56	82	28	68	166
4	75	90-600	180-1200	1100-1600	1920	3840	–	55	95	160	185	85	80	40	78	205
5	90	400-800	800-1600	1400-2100	3600	7200	–	65	110	200	260	100	114	45	92	259
6	100	300-1200	600-2400	–	4950	9900	38	80	115	225	285	110	130	50	102	290
7	110	600-2200	1200-4400	–	7200	14400	45	100	125	255	330	120	142	55	113	317
8	140	900-3400	1800-6800	–	12800	25600	58	120	160	320	410	155	152	65	115	372
9	160	2500-6000	6000-12000	–	19200	38400	65	140	185	370	460	175	199	75	161	449

¹⁾ The figure in brackets specifies the max. bore with keyway to DIN 6885 sheet 3 (low-rise design)

²⁾ With clamping setting nut to be used on types limited in dimensions only

³⁾ See selection of ROTEX® couplings on page 14 et seqq.

⁴⁾ With special disk spring

Ordering example:	RUFLEX® 1	2TF	d Ø20	ROTEX® 28	98 ShA	d ₁ Ø25	100 Nm
	Type/size	Disk spring layering	RUFLEX® bore	Type/size	Spider	ROTEX® bore	Torque set

RUFLEX® Torque limiters

With torsionally stiff BoWex®



For legend of pictogram please refer to flapper on the cover

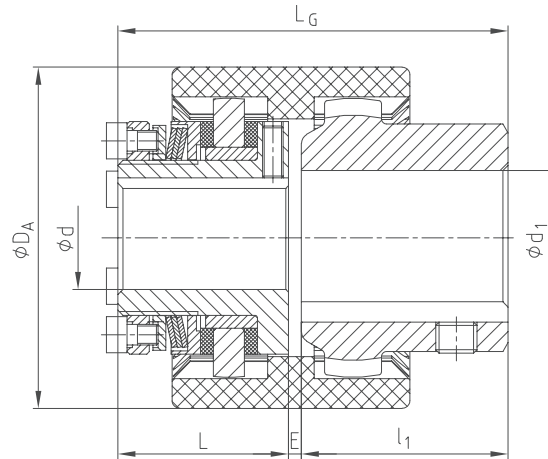

Technical data – dimensions													
RUFLEX® size	BoWex® size	RUFLEX® Torques [Nm]			BoWex® ³⁾ Torques [Nm]		Dimensions [mm]						
		1TF	2TF	3TF ²⁾	T _{KN}	T _{K max}	Max. bore		D _A	l ₁	L	E	L _G
00	19	(0.5) ⁴⁾ 1-3	2-5	–	16	32	d	d ₁	48	25.0	31	2.5	58.5
0	28	2-10	4-20	–	45	90	19 (20) ¹⁾	28	66	40.0	33	2.5	75.5
01	38	5-35	10-70	–	80	160	22	38	83	35.5	45	1.0	81.5
1	48	20-75	40-150	130-200	140	280	25	48	95	45.5	52	1.0	98.5
2	65	25-140	50-280	250-400	380	760	35	65	132	64.0	57	1.0	122

¹⁾ The figure in brackets specifies the max. bore with keyway to DIN 6885 sheet 3 (low-rise design)

²⁾ With clamping setting nut to be used on types limited in dimensions only

³⁾ See selection of BoWex® couplings on page 14 et seqq.

⁴⁾ With special disk spring

Ordering example:	RUFLEX® 1	1TF	d Ø20	BoWex® 48	d ₁ Ø25	50 Nm
	Type/size	Disk spring layering	RUFLEX® bore	Type/size	BoWex® bore	Torque set