

BACKLASH FREE SERVO DISC PACK COUPLINGS 25 – 100 Nm

MODEL	FEATURES	Page 66
 <p>SCL2 S</p>	<p>with clamping hub single flex coupling</p> <ul style="list-style-type: none"> ▶ very high torsional stiffness ▶ compact design ▶ low moment of inertia 	Page 66
 <p>SCL2 D</p>	<p>with clamping hub double flex coupling</p> <ul style="list-style-type: none"> ▶ high torsional stiffness ▶ low moment of inertia ▶ lateral misalignment compensation 	Page 66
 <p>SCL3 S</p>	<p>with conical clamping system single flex coupling</p> <ul style="list-style-type: none"> ▶ very high concentricity ▶ high clamping pressure ▶ low moment of inertia 	Page 67
 <p>SCL3 D</p>	<p>with conical clamping system double flex coupling</p> <ul style="list-style-type: none"> ▶ high concentricity ▶ high clamping pressure ▶ high torsional stiffness 	Page 67

SERVO DISC PACK COUPLINGS

SYMBOLS

- T_{KN} = Rated torque of the coupling (Nm)
- T_{AS} = Peak torque of the drive system e.g. max. acceleration torque of drive (Nm) or max. braking torque of load (Nm)
- J_L = Total load inertia (e.g. spindle + slide + workpiece + 1/2 of coupling) (kgm²)
- J_A = Total driving inertia (motor [including gear ratio] + 1/2 of coupling) (kgm²)
- C_T = Torsional stiffness of the coupling (Nm/rad)
- f_e = Natural frequency of the two mass system (Hz)

ACCORDING TO TORQUE

Couplings are normally sized for the highest torque to be regularly transmitted. The peak torque of the application should not exceed the rated torque of the coupling. The following calculation provides an approximation of the minimum required coupling size, and allows for the maximum rated speed and misalignment to exist in the application:

$$T_{KN} \cong 1.5 \cdot T_{AS} \text{ (Nm)}$$

ACCORDING TO ACCELERATION TORQUE

A more detailed calculation takes acceleration and the driving and driven moments of inertia into account. A strong inertia ratio diminishes the effect of the load factor in the sizing calculation.

$$T_{KN} \cong T_{AS} \cdot \frac{J_L}{J_A + J_L} \text{ (Nm)}$$

ACCORDING TO RESONANT FREQUENCY

The torsional natural frequency of the coupling must be significantly higher or lower than that of the equipment. For the mechanical substitution model the two mass system applies.

$$f_e = \frac{1}{2 \cdot \pi} \sqrt{C_T \cdot \frac{J_A + J_L}{J_A \cdot J_L}} \text{ (Hz)}$$

In practice the following applies: $f_e \geq 2 \cdot f_{er}$

Two Mass System

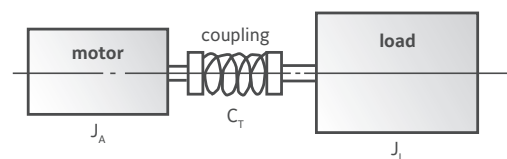

SCL2

WITH CLAMPING HUB 25 - 100 Nm



NEW

PROPERTIES

FEATURES

- ▶ high torsional stiffness
- ▶ low inertia
- ▶ backlash free

MATERIAL

- ▶ **Disc packs:** highly elastic steel
- ▶ **Hubs and spacer:** aluminium

DESIGN

Two precision machined coupling hubs and precision spacer mounted to the disc packs by means of high strength screws and spacers for frictional clamping of the assembly.

Also available as split clamping hub.

S = Single flex coupling

D = Double flex coupling

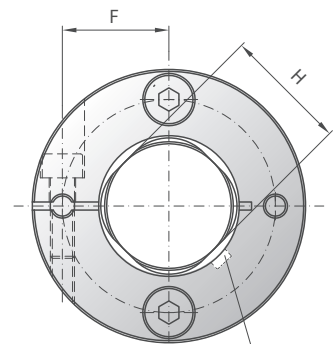
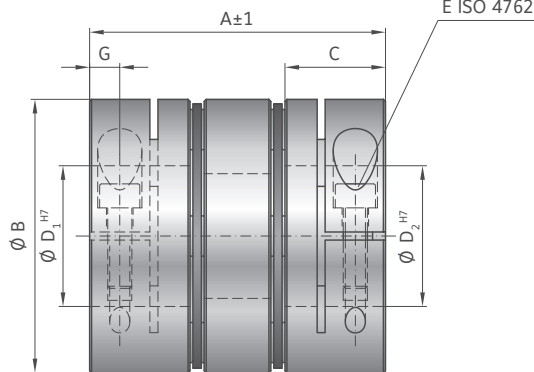
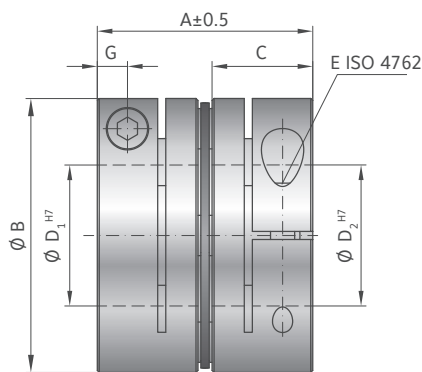

MODEL SCL2

SIZE			25		40		60		100	
System			S	D	S	D	S	D	S	D
Rated torque	(Nm)	T_{KN}	25		40		60		100	
Maximum torque	(mm)	T_{Kmax}	37.5		60		90		150	
Coupling length	(mm)	A	43.6	60.2	50.9	69.3	53.5	73.6	68.7	98.8
Outside diameter	(mm)	B	56		63		68		82	
Fit length	(mm)	C	20.2		24		25		30	
Bore diameter H7	(mm)	D_1 / D_2	15-30		16-30		25-35		26-40	
Fastening screw		E	M5		M6		M6		M8	
Tightening torque	(Nm)		8		15		15		30	
Distance	(mm)	F	22		23		26.5		28	
Distance	(mm)	G	6		7.5		7.5		8.5	
Shaft diameter limitation	(mm)	H	26		-		31		38	
Moment of inertia	(10^{-3} kgm^2)	J_{ges}	0.095	0.138	0.182	0.256	0.260	0.373	0.706	1.036
Weight	(kg)		0.192	0.284	0.304	0.428	0.363	0.531	0.694	1.022
Torsional stiffness	(Nm/rad)	C_T	46000	23000	58000	29000	82000	41000	157000	78500
Axial displacement	± (mm)		0.4	0.81	0.42	0.85	0.5	1	0.5	1.15
Lateral displacement	± (mm)	max. values	-	0.29	-	0.32	-	0.35	-	0.53
Angular displacement	± (degree)		1	2	1	2	1	2	1	2
Max. speed	(1/min)		10000							

ORDERING EXAMPLE	SCL2	60	D	28	33	XX
Model	●					
Size		●				
System			●			
Bore Ø D1 H7				●		
Bore Ø D2 H7					●	
Special designation only (e.g. balanced G2.5)						

For custom features place an XX at the end of the part number and describe the special requirements (SCL2 / 60 / D / 28 / 33 / XX)

SCL3

WITH EXTERNAL CLAMPING RING

25 - 100 Nm

PROPERTIES



NEW

FEATURES

- ▶ high torsional stiffness
- ▶ low inertia
- ▶ backlash free
- ▶ low imbalance

DESIGN

Two precision machined coupling hubs and precision spacer mounted to the disc packs by means of high strength screws and spacers for frictional clamping of the assembly.

MATERIAL

- ▶ **Disc packs:** highly elastic spring steel
- ▶ **Hubs and spacer:** aluminium

S = Single flex coupling

D = Double flex coupling

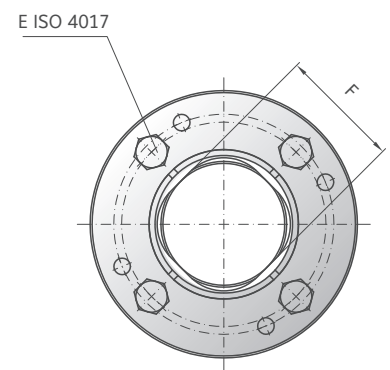
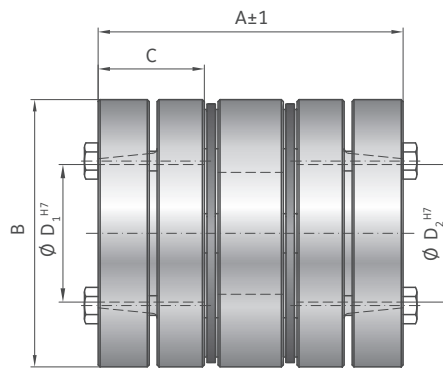
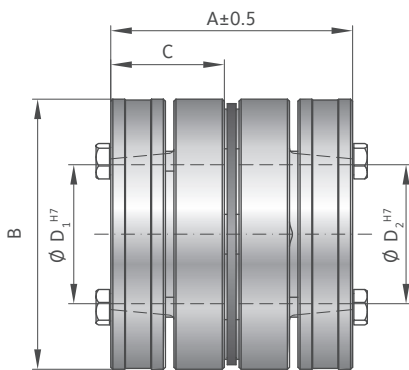

MODEL SCL3

SIZE		25		40		60		100	
System		S	D	S	D	S	D	S	D
Rated torque (Nm)	T_{KN}	25		40		60		100	
Maximum torque (mm)	T_{Kmax}	37.5		60		90		150	
Coupling length (mm)	A	56.6	73.2	56.9	75.3	57.5	77.6	73.7	103.8
Outside diameter (mm)	B	56		63		68		82	
Fit length (mm)	C	27		27		27		32.5	
Bore diameter H7 (mm)	D_1 / D_2	18-28		20-30		27-35		24-40	
Fastening screw	E	M5		M5		M5		M5	
Tightening torque (Nm)		5.5		6		6		6	
Shaft diameter limitation (mm)	F	26		-		31		38	
Moment of inertia (10^{-3} kgm^2)	J_{ges}	0.144	0.187	0.230	0.304	0.310	0.422	0.837	1.170
Weight (kg)		0.299	0.390	0.384	0.508	0.435	0.603	0.835	1.156
Torsional stiffness (Nm/rad)	C_T	46000	23000	58000	29000	82000	41000	157000	78500
Axial displacement ± (mm)		0.4	0.81	0.42	0.85	0.5	1	0.55	1.15
Lateral displacement ± (mm)	max. values	-	0.29	-	0.32	-	0.35	-	0.53
Angula displacement ± (degree)		1	2	1	2	1	2	1	2
Max. speed (1/min)		10000							

ORDERING EXAMPLE	SCL3	60	D	28	33	XX
Model	●					Special designation only (e.g. balanced G2.5)
Size		●				
System			●			
Bore Ø D1 H7				●		
Bore Ø D2 H7					●	

For custom features place an XX at the end of the part number and describe the special requirements (SCL3 / 60 / D / 28 / 33 / XX)

SERVO DISC PACK
COUPLINGS SCL