

Barrel Couplings

RINGFEDER® TNK TKV

Power improved series

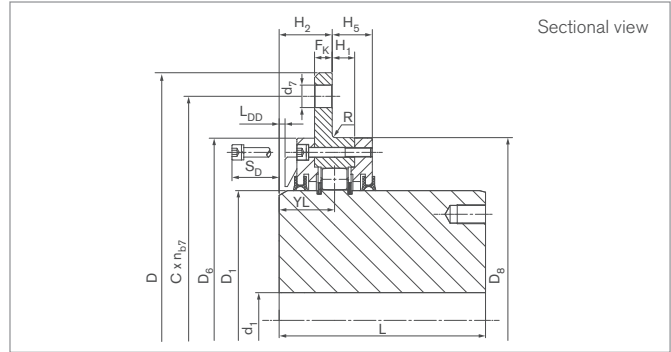
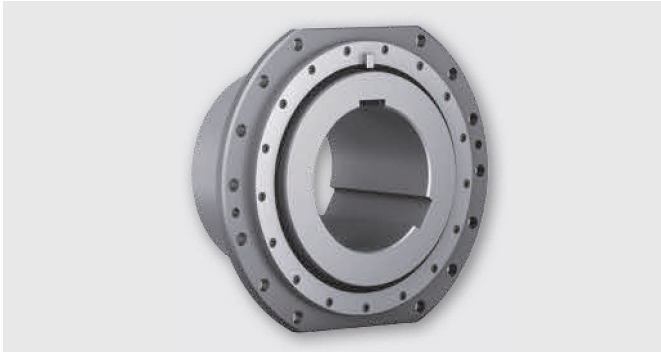

Identifier	Size	T _{Kmax}	F _{rad}	d _{1kmin}	d _{1kmax}	D	L	L _{min}	D ₁	D ₆	D ₈	H ₁	R	H ₂	F _K	H ₅	YL
		Nm	N	mm	mm	mm	mm	mm	mm	mm	mm	mm	mm	mm	mm	mm	mm
WG7125	25	6500	17500	20	66	250	95	85	95	159	160	16	2,5	42	12	31	44,0
WG7128	50	8400	20000	20	77	280	100	85	110	179	180	16	2,5	42	12	31	44,0
WG7132	75	10500	21500	20	88	320	110	95	125	199	200	17	2,5	45	15	32	46,0
WG7134	100	16000	28000	20	98	340	125	95	140	219	220	17	2,5	45	15	32	46,0
WG7136	130	21500	37000	47	112	360	130	95	160	239	240	19	2,5	45	15	34	47,0
WG7138	160	27000	42500	47	126	380	145	95	180	259	260	19	2,5	45	15	34	47,0
WG7140	200	31500	48000	47	140	400	170	95	200	279	280	19	2,5	45	15	34	47,0
WG7142	300	39000	53000	47	155	420	175	95	220	309	310	19	2,5	45	15	34	47,0
WG7145	400	53500	75000	47	183	450	185	120	260	339	340	22	2,5	60	20	40	61,0
WG7151	500	91000	118000	77	210	510	220	125	295	399	400	22	2,5	60	20	42	61,0
WG7155	600	127000	132000	77	220	550	240	125	310	419	420	22	2,5	60	20	42	61,0
WG7158	1000	180000	145000	102	250	580	260	130	350	449	450	22	2,5	60	20	42	61,0
WG7165	1500	241000	184000	102	295	650	315	140	415	529	530	27	2,5	65	25	47	66,0
WG7166	2100	360000	283000	102	305	665	330	145	430	544	545	34	4,0	65	25	54	69,5
WG7168	2600	425000	330000	102	315	680	350	145	445	559	560	34	4,0	65	25	54	69,5
WG7171	3400	529000	366000	178	335	710	380	165	475	599	600	34	4,0	81	35	59	85,5
WG7178	4200	660000	420000	208	380	780	410	165	535	669	670	34	4,0	81	35	59	85,5
WG7185	6200	815000	490000	238	425	850	450	165	600	729	730	34	4,0	81	35	59	85,5

To continue see next page

Barrel Couplings RINGFEDER® TNK TKV

Identifier	Size	C	n _{b7}	d ₇	S (h9/F8)	S _D	G _G	L _{DD}	X _a	J _{sb}	G _{w_{sb}}
		mm		mm	mm	mm	inch	mm	mm	10 ⁻³ kgm ²	kg
WG7125	25	220	10	15	220	50	G1/8	5	+/-3	60	12
WG7128	50	250	10	15	250	50	G1/8	5	+/-3	90	16
WG7132	75	280	10	19	280	60	G1/8	5	+/-4	170	23
WG7134	100	300	10	19	300	60	G1/8	5	+/-4	230	29
WG7136	130	320	10	19	320	60	G1/8	5	+/-4	320	35
WG7138	160	340	10	19	340	60	G1/8	5	+/-4	440	45
WG7140	200	360	10	19	360	60	G1/8	5	+/-4	610	59
WG7142	300	380	10	19	380	60	G1/8	5	+/-4	850	73
WG7145	400	400	10	24	400	70	G1/4	9	+/-4	1450	101
WG7151	500	460	10	24	460	70	G1/4	7	+/-6	2860	152
WG7155	600	500	10	24	500	70	G1/4	7	+/-6	3730	180
WG7158	1000	530	14	24	530	70	G1/4	7	+/-6	5350	228
WG7165	1500	600	14	24	580	80	G1/4	7	+/-6	11640	379
WG7166	2100	615	26	24	590	90	G1/4	7	+/-6	13790	426
WG7168	2600	630	26	24	600	90	G1/4	7	+/-6	16070	477
WG7171	3400	660	26	28	640	90	G1/4	13	+/-8	22730	545
WG7178	4200	730	26	28	700	90	G1/4	13	+/-8	35260	725
WG7185	6200	800	26	28	760	90	G1/4	13	+/-8	59650	961

Explanations

T_{Kmax} = Max. transmissible torque of the coupling	D₆ = Diameter	d₇ = Bore diameter
F_{rad} = Admissible force radial	D₈ = Outer diameter	S (h9/F8) = Distance of the flattening
d_{1kmin} = Min. bore diameter d ₁ with keyway acc. to DIN 6885-1	H₁ = Length	S_D = Disassembly Space
d_{1kmax} = Max. bore diameter d ₁ with keyway acc. to DIN 6885-1	R = Radius	G_G = Whitworth thread
D = Outer diameter	H₂ = Distance	L_{DD} = Distance dimension
L = Total length	F_K = Flange thickness	X_a = Axial gap max.
L_{min} = Minimum length	H₅ = Distance	J_{sb} = Moment of inertia at smallest bore diameter
D₁ = Outer diameter	Y_L = Distance	G_{w_{sb}} = Weight at smallest bore diameter
	C = Pitch circle diameter	
	n_{b7} = Quantity of bore d ₇	

Ordering example

Identifier	Size	d _{1k}
WG7155	600	190

Further information on
RINGFEDER® TNK TKV
 on www.ringfeder.com

Disclaimer of liability

All technical details and notes are non-binding and cannot be used as a basis for legal claims. The user is obligated to determine whether the represented products meet his requirements. We reserve the right carry out modifications at any time in the interests of technical progress.

Barrel Couplings

RINGFEDER® TNK TKVSG

Power improved SEB series

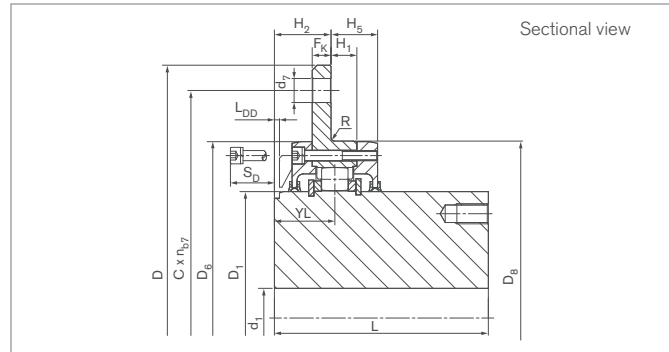
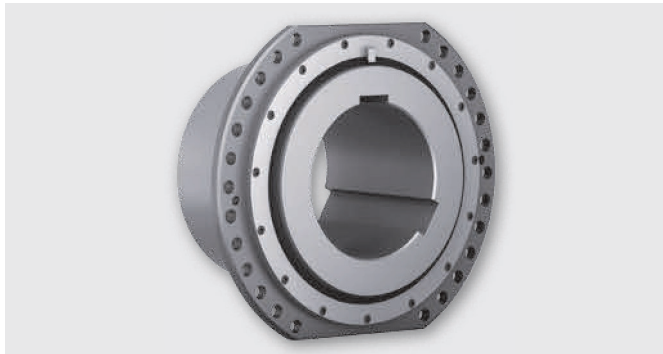

Identifier	SEB 666212	Size	T _{Kmax}	F _{rad}	d _{1kmin}	d _{1kmax}	D	L	L _{min}	D ₁	D ₆	D ₈	H ₁	R	H ₂	F _K	H ₅	YL
			Nm	N	mm	mm	mm	mm	mm	mm	mm	mm	mm	mm	mm	mm	mm	mm
WG7340	SG130	200	31500	48000	47	140	400	170	100	200	279	280	20,5	2,5	45	15	37,0	48,0
WG7342	(*)	300	39000	53000	47	155	420	175	100	220	309	310	25,0	2,5	45	15	40,0	50,0
WG7345	SG140	400	53500	75000	47	183	450	185	120	260	339	340	21,0	2,5	60	20	39,0	60,5
WG7351	(*)	500	91000	118000	77	210	510	220	135	295	399	400	29,0	2,5	60	20	49,0	64,5
WG7355	SG185	600	127000	132000	77	220	550	240	135	310	419	420	29,0	2,5	60	20	49,0	64,5
WG7358	SG200	1000	180000	145000	102	250	580	260	140	350	449	450	29,5	2,5	60	20	49,5	65,0
WG7365	SG240	1500	241000	184000	102	295	650	315	145	415	529	530	31,5	2,5	65	25	51,5	68,5
WG7366	(*)	2100	360000	283000	102	305	665	330	155	430	544	545	43,0	4,0	65	25	64,0	74,0
WG7368	SG270	2600	425000	330000	102	315	680	350	155	445	559	560	43,0	4,0	65	25	64,0	74,0
WG7371	SG315	3400	529000	366000	178	335	710	380	175	475	599	600	38,0	4,0	81	35	63,0	86,0
WG7378	SG355	4200	660000	420000	208	380	780	410	175	535	669	670	40,0	4,0	81	35	66,0	87,5
WG7385	SG400	6200	815000	490000	238	425	850	450	175	600	729	730	42,0	4,0	81	35	66,0	87,5
WG7394	(*)	8200	930000	525000	---	460	940	500	191	650	796	800	44,0	4,0	86	40	62,0	92,0
WG7310	(*)	9200	1100000	550000	---	490	1025	500	191	695	856	860	44,0	4,0	86	40	62,0	92,0
WG7311	(*)	10200	1390000	670000	---	550	1120	500	191	780	946	950	44,0	4,0	86	40	62,0	92,0

*Construction and design acc. to operation sheet of German Steel Iron Industry SEB 666212

To continue see next page

Barrel Couplings RINGFEDER® TNK TKVSG

Identifier	SEB 666212	Size	C	n _{b7}	d ₇	S (h9/F8)	S _D	G _G	L _{DD}	X _a	J _{sb}	G _{w_{sb}}
			mm		mm	mm	mm	inch	mm	mm	10 ⁻³ kgm ²	kg
WG7340	SG130	200	360	10	19	360	60	G1/8	4	+/-4	630	60
WG7342	(*)	300	380	10	19	380	60	G1/8	5	+/-4	870	74
WG7345	SG140	400	400	10	24	400	70	G1/4	9	+/-4	1450	101
WG7351	(*)	500	460	10	24	460	70	G1/4	7	+/-6	2920	154
WG7355	SG185	600	500	10	24	500	70	G1/4	7	+/-6	3790	182
WG7358	SG200	1000	530	14	24	530	70	G1/4	7	+/-6	5410	227
WG7365	SG240	1500	600	14	24	580	80	G1/4	7	+/-6	11680	380
WG7366	(*)	2100	615	26	24	590	90	G1/4	6	+/-6	13900	427
WG7368	SG270	2600	630	26	24	600	90	G1/4	6	+/-6	16550	478
WG7371	SG315	3400	660	26	28	640	90	G1/4	10	+/-8	22930	548
WG7378	SG355	4200	730	26	28	700	90	G1/4	10	+/-8	37480	725
WG7385	SG400	6200	800	26	28	760	90	G1/4	10	+/-8	59580	960
WG7394	(*)	8200	875	32	28	830	95	G1/4	10	+/-10	88210	1011
WG7310	(*)	9200	945	32	34	900	95	G1/4	10	+/-10	118920	1062
WG7311	(*)	10200	1040	32	34	1000	95	G1/4	10	+/-10	181970	1315

*Construction and design acc. to operation sheet of German Steel Iron Industry SEB 666212

Explanations

T_{Kmax} = Max. transmissible torque of the coupling	D₆ = Diameter	d₇ = Bore diameter
F_{rad} = Admissible force radial	D₈ = Outer diameter	S (h9/F8) = Distance of the flattening
d_{1kmin} = Min. bore diameter d ₁ with keyway acc. to DIN 6885-1	H₁ = Length	S_D = Disassembly Space
d_{1kmax} = Max. bore diameter d ₁ with keyway acc. to DIN 6885-1	R = Radius	G_G = Whitworth thread
D = Outer diameter	H₂ = Distance	L_{DD} = Distance dimension
L = Total length	F_K = Flange thickness	X_a = Axial gap max.
L_{min} = Minimum length	H₅ = Distance	J_{sb} = Moment of inertia at smallest bore diameter
D₁ = Outer diameter	Y_L = Distance	G_{w_{sb}} = Weight at smallest bore diameter
	C = Pitch circle diameter	
	n_{b7} = Quantity of bore d ₇	

Ordering example

Identifier	Size	d _{1k}
WG7378	4200	340

Further information on
RINGFEDER® TNK TKVSG
 on www.ringfeder.com

Disclaimer of liability

All technical details and notes are non-binding and cannot be used as a basis for legal claims. The user is obligated to determine whether the represented products meet his requirements. We reserve the right carry out modifications at any time in the interests of technical progress.