

TOOLFLEX®

Metal bellow-type couplings

Technical description

TOOLFLEX® is a metal bellow-type coupling, a coupling system which has proven in the field with numerous applications. The metal bellow compensates perfectly for axial, radial and angular displacements. At the same time its geometric shape allows for high torsional stiffness and a low mass moment of inertia. TOOLFLEX® is manufactured in twelve sizes for maximum torques up to 600 Nm. Its main application ranges are both positioning drives, e. g. ball spindles with a high incline, and indexing tables or planetary and worm gears with small gear ratios.

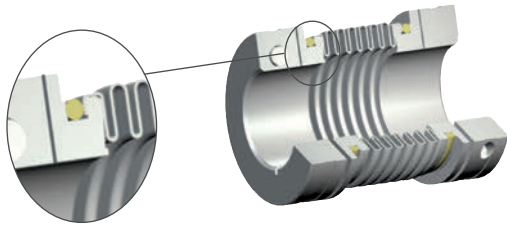

Subject to its proven bonding technique a non-positive, backlash-free connection of the aluminium hubs with the multilayer bellows made of stainless steel is generated. The flanged insert connection for sizes 16 to 55 ensures torque transmission of every single bellow layer. Since TOOLFLEX® is a metal coupling, it remains fatigue-endurable in the high-temperature range up to a maximum of 200 °C. Apart from that it is resistant to the effect of media or critical operating conditions, respectively.

The renowned shaft-hub-connection by means of clamping hubs ensures an easy assembly by a radial clamping screw. Subject to two slots in the hub there is no deformation of the bellow when tightening the clamping screw. For higher friction torques type KN with taper hubs can be used.

Double slotted clamping hub

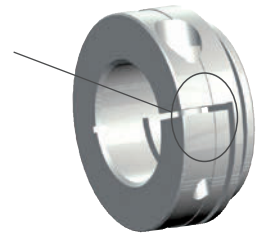

Types



Type with setscrew



Type with clamping hubs



Type KN



Type PI



Type CF

Summary																																																	
Size	Type	Bel-low-hub-connection	Setscrew (hub type 1.0/1.1)			Clamping hubs (hub type 2.5/2.6)			KN			PI			CF																																		
			Torque of bellow T _{KN} [Nm]	Torque of bellow T _K max [Nm]	Max. speed [rpm]	Torque of bellow T _{KN} [Nm]	Torque of bellow T _K max [Nm]	Max. speed [rpm]	Torque of bellow T _{KN} [Nm]	Torque of bellow T _K max [Nm]	Max. speed [rpm]	Torque of bellow T _{KN} [Nm]	Torque of bellow T _K max [Nm]	Max. speed [rpm]	Torque of bellow T _{KN} [Nm]	Torque of bellow T _K max [Nm]	Max. speed [rpm]																																
5	S	Bonded Maximum ambient temperature 100 °C	0.1	0.15	47700	1	1.5	31800																																									
	M																																																
7	S																Bonded Maximum ambient temperature 100 °C	1	1.5	31800	1	1.5	31800																										
	M																																																
9	S																															Bonded Maximum ambient temperature 100 °C	1.5	2.25	23800	1.5	2.25	23800											
	M																																																
12	S	Bonded Maximum ambient temperature 100 °C	2	3	19000	2	3	19100																																									
	M																																																
16	S																Bonded Maximum ambient temperature 100 °C	5	7.5	14900	5	7.5	14900																										
	M																																																
20	S																															Bonded Maximum ambient temperature 100 °C	15	22.5	11900	15	22.5	11950				15	22.5	11950					
	M																																																
30	S	Flanged Maximum ambient temperature 200 °C				35	52.5	8700	35	52.5	15280	35	52.5	8700	35	52.5																															8700		
	M																																																
38	S																Flanged Maximum ambient temperature 200 °C				65	97.5	7350	65	97.5	12600	65	97.5	7350	65	97.5																	7350	
	M																																																
42	S																															Flanged Maximum ambient temperature 200 °C				95	142.5	6820	95	142.5	11580	95	142.5	6820	95	142.5			6820
	M																																																
45	S	Flanged Maximum ambient temperature 200 °C				170	255	5750	170	255	9300	170	255	5750	170	255																															5750		
	M																																																
55 Al	S																Welded Maximum ambient temperature 200 °C				340	510	4800																										
	M																																																
55	S																															Welded Maximum ambient temperature 200 °C				340	510	4800	340	510	7870	340	510	4800					
	M																																																
65	S	Welded Maximum ambient temperature 200 °C				600	900	3850																																									
	M																																																

TOOLFLEX®

Metal bellow-type couplings

Types of hubs

Due to the use of TOOLFLEX® for many different applications and mounting situations, this coupling system is available with various hub types and two different lengths of bellows. A combination of the components forms a type.

TOOLFLEX® is supplied as a complete unit; a supply of individual components is not possible.



Type 1.0
with feather keyway and setscrew
Positive-locking power transmission. Permissible torque depending on the permissible surface pressure. Not suitable for backlash-free power transmission with heavily reversing operation.



Type 1.1
without feather keyway, with setscrew
Non-positive torque transmission. Suitable for backlash-free transmission of very small torques.



Type 1.3
with spline bore
Positive-locking power transmission. Spline on request of customers (e. g. for shaft with flattening).

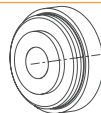

Type 1.2
without feather keyway, without setscrew
For low torques. Suitable for bonding or pressing onto the shaft.



Type 2.5 clamping hub
double slotted, without feather keyway
Frictionally engaged, backlash-free shaft-hub-connection. Transmittable torques depending on bore diameter.



Type 2.6 clamping hub
double slotted, with feather keyway
Positive-locking power transmission with additional friction fit. The friction fit avoids or reduces reverse backlash. Surface pressure of the keyway connection is reduced.

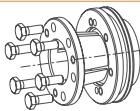

Type 6.5 taper hub KN
Integrated frictionally engaged shaft-hub-connection for the transmission of higher torques in the area of the shaft-hub-connection.



Flange
Flange to connect to customer's component. Special dimensions on request.



Type 7.5 clamping hub type DH
without feather keyway for double-cardanic connection
Frictionally engaged, backlash-free shaft-hub-connection for radial assembly of coupling. Transmittable torques depending on bore diameter.



Type 7.6 clamping hub type DH
with feather keyway for double-cardanic connection
Positive-locking power transmission with additional friction fit for radial assembly of coupling. The friction fit avoids or reduces reverse backlash. Surface pressure of the keyway connection is reduced.

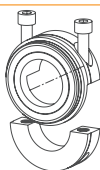

Type 7.8 clamping hub type H
without feather keyway for single-cardanic connection
Frictionally engaged, backlash-free shaft-hub-connection for radial assembly of coupling. Transmittable torques depending on bore diameter.

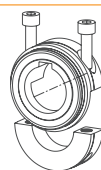

Type 7.9 clamping hub type H
with feather keyway for single-cardanic connection
Positive-locking power transmission with additional friction fit for radial assembly of coupling. The friction fit avoids or reduces reverse backlash. Surface pressure of the keyway connection is reduced.

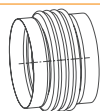

Bellow type S
Bellow with 4 layers made of stainless steel; compact design with high torsion spring stiffness.

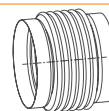

Bellow type M
Bellow with 6 layers made of stainless steel; realizing large shaft distance dimensions and displacements.

Special designs on request of customers

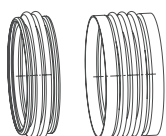

Special bellows
Bellows with 1, 2 or 3 layers available on request.

TOOLFLEX® S

Metal bellow-type couplings

Type S: Hubs with setscrews



For legend of pictogram please refer to flapper on the cover

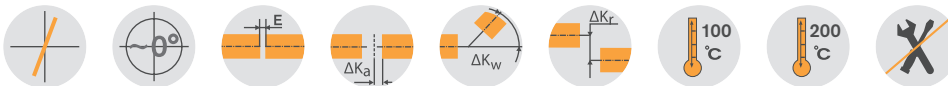

TOOLFLEX® S type 1.1

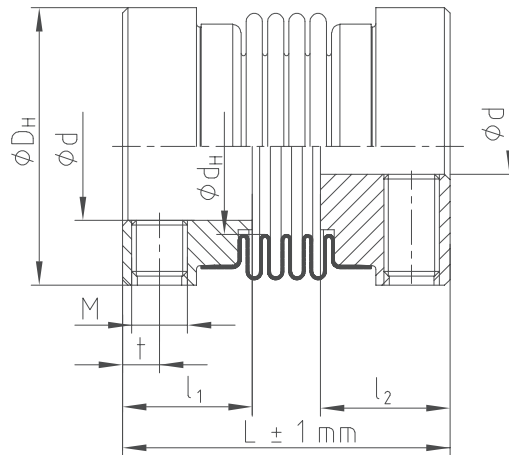

TOOLFLEX® S with setscrew (type 1.1) - Hub material aluminium/bellow material stainless steel

Size	Bellow- hub-connection	Torque of bellow T _{KN} 1) [Nm]	Max. speed [rpm]	Dimensions [mm]									Perm. displacements			Torsion spring stiff- ness C _T [Nm/rad]	Weight 3) [kg]
				Finish bore d		General				Setscrew			Axial [mm]	Radial [mm]	Angular [degree]		
				Min.	Max.	D _H	d _H	L	l ₁ , l ₂	M	t	z = num- ber 2)					
5		0.1	47700	2	5	10	6	15	6	M2	1.8	1	±0.30	0.10	0.7	97	0.0027
7	4)	1.0	31800	3	8	15	9	18	7	M3	2.0	1	±0.30	0.10	0.7	390	0.005
9		1.5	23800	3	10	20	12	21	8	M3	2.2	2	±0.35	0.15	1.0	750	0.010
12		2.0	19000	4	14	25	16	27.5	11	M4	2.8	2	±0.40	0.15	1.0	1270	0.017
16		5.0	14900	5	18	32	20	37	13	M5	4	2	±0.30	0.15	1.0	4500	0.046
20	5)	15	11900	6	25	40	27	42	15	M5	5	2	±0.40	0.15	1.0	9600	0.076

1) For selection see page 22 et seqq.

2) Number each hub; from size 9: 2 x 120° offset.

3) Figures refer to the complete coupling with max. bore.

4) Bonded

5) Flanged

Types of hubs

Type 1.0

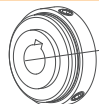

Hub with feather keyway and setscrew

Type 1.1

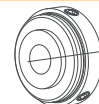

Hub without feather keyway, with setscrew

Type 1.2

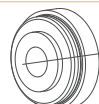

Hub without feather keyway, without setscrew

Type 1.3

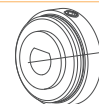

Hub with spline bore

Ordering
example:

TOOLFLEX® 7 S	1.1 - Ø4		1.1 - Ø6	
Size and type of coupling	Hub type	Finish bore	Hub type	Finish bore

TOOLFLEX® M

Metal bellow-type couplings

Type M: Hubs with setscrews

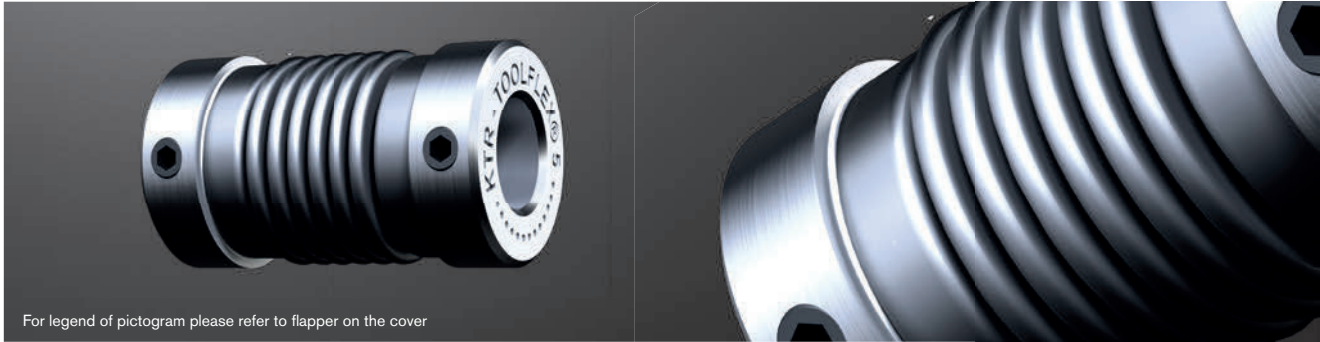

For legend of pictogram please refer to flapper on the cover

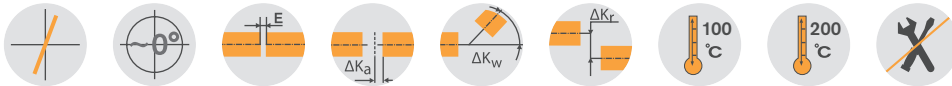

TOOLFLEX® M type 1.1

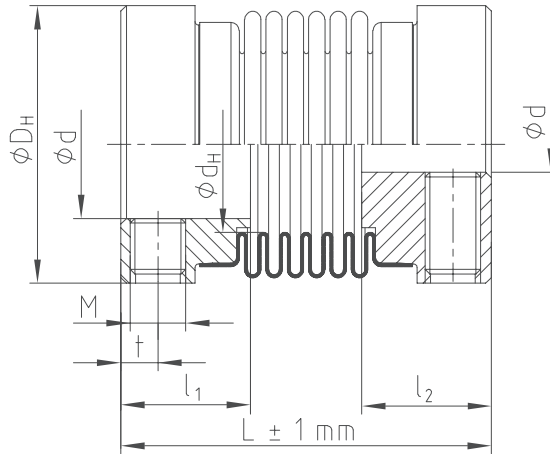

TOOLFLEX® M with setscrew (type 1.1) - Hub material aluminium/bellow material stainless steel

Size	Bellow-connection	Torque of bellow T _{KN} ¹⁾ [Nm]	Max. speed [rpm]	Dimensions [mm]										Perm. displacements			Torsion spring stiffness C _T [Nm/rad]	Weight ³⁾ [kg]
				Finish bore d		General				Setscrew				Axial [mm]	Radial [mm]	Angular [degree]		
				Min.	Max.	D _H	d _H	L	l ₁ , l ₂	M	t	z = number ²⁾						
5		0.1	47700	2	5	10	6	17	6	M2	1.8	1	±0.40	0.15	1.0	75	0.003	
7	4)	1.0	31800	3	8	15	9	20	7	M3	2.0	1	±0.40	0.15	1.0	300	0.006	
9		1.5	23800	3	10	20	12	24	8	M3	2.2	2	±0.50	0.20	1.5	580	0.011	
12		2.0	19000	4	14	25	16	31	11	M4	2.8	2	±0.60	0.20	1.5	980	0.019	
16		5.0	14900	5	18	32	20	41	13	M5	4	2	±0.50	0.20	1.5	3050	0.049	
20	5)	15	11900	6	25	40	27	49	15	M5	5	2	±0.60	0.20	1.5	6600	0.082	

¹⁾ For selection see page 22 et seqq.

²⁾ Number each hub; from size 9: 2 x 120° offset.

³⁾ Figures refer to the complete coupling with max. bore.

⁴⁾ Bonded

⁵⁾ Flanged

Types of hubs

Type 1.0

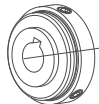

Hub with feather keyway and setscrew

Type 1.1

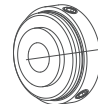

Hub without feather keyway, with setscrew

Type 1.2

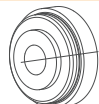

Hub without feather keyway, without setscrew

Type 1.3

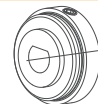

Hub with spline bore

Ordering example:

TOOLFLEX® 7 M	1.1 - Ø4		1.1 - Ø6	
Size and type of coupling	Hub type	Finish bore	Hub type	Finish bore

TOOLFLEX® S

Metal bellow-type couplings

Type S: with clamping hubs

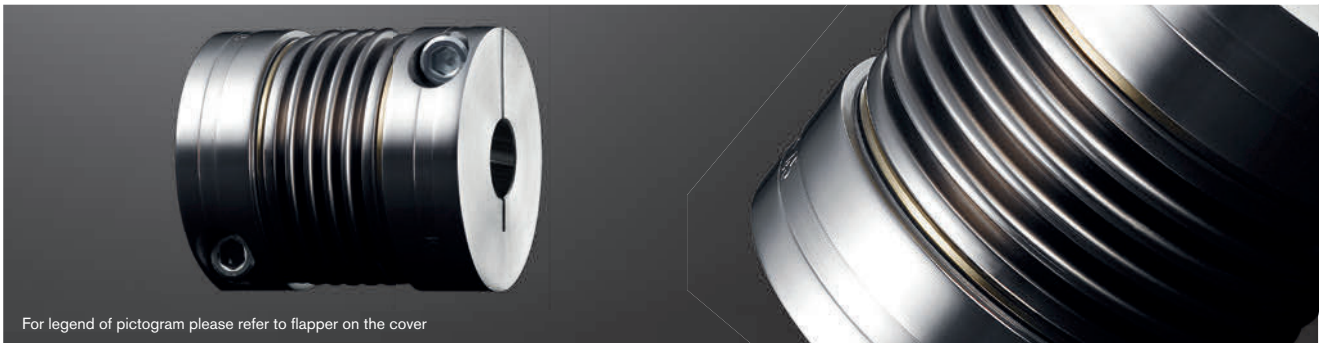

For legend of pictogram please refer to flapper on the cover

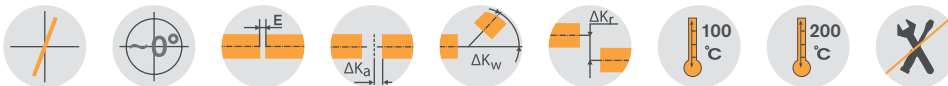

TOOLFLEX® Type S with clamping hubs - Hub material aluminium (size 55/65 steel)/bellow material stainless steel

Size	Dimensions [mm]											
	Finish bore d		General					Clamping screws DIN EN ISO 4762				
	Min.	Max.	L	l ₁ , l ₂	E	D _H	d _H	M ₁	DK	t ₁	e ₁	T _A [Nm]
7	3	7	24	9	6	15	9	M2	16.5	3.2	5	0.37
9	3	9	29	11	7	20	12	M2.5	21.5	3.5	7.1	0.76
12	4	12	34.5	13	8.5	25	16	M3	26.5	4	8.5	1.34
16	5	16	45	17.0	11	32	20	M4	35.0	5	12.0	2.9
20	8	20	55	21.5	12	40	27	M5	43.5	6	14.5	6
30	10	30	63	23.0	17	55	33	M6	58.0	7	19	10
38	12	38	69	25.5	18	65	42	M8	72.6	9	25	25
42	14	42	84	30.0	24	70	46	M8	76.1	9	27	25
45	14	45	86.5	32.0	22.5	83	58	M10	89.0	11	30	49
55 Al	20	55	111	40.0	31	100	73	M12	106.0	14	37	86
55 ³⁾	20	55	111	40.0	31	100	73	M12	106.0	14	37	120
65 ³⁾	30	65	126	45.0	36	125	95	M14	127.2	15	45	185

Technical data

Size	Bellow-hub-connection	Torque of bellow T _{KN} ¹⁾ [Nm]	Max. speed [rpm]	Hub material	Moment of inertia ²⁾ [x10 ⁻⁶ kgm ²]	Torsion spring stiffness C _T [Nm/rad]	Axial stiffness C _a [N/mm]	Radial stiffness C _r [N/mm]	Perm. displacements			Weight ²⁾ [kg]
									Axial [mm]	Radial [mm]	Angular [degree]	
7	Bonded	1	31800	Aluminium	0.26	390	—	—	±0.3	0.10	0.7	0.007
9		1.5	23800	Aluminium	0.97	750	—	—	±0.35	0.15	1.0	0.014
12		2	19100	Aluminium	2.6	1270	—	—	±0.4	0.15	1.0	0.025
16		5	14900	Aluminium	9	4500	43	138	±0.3	0.15	1.0	0.06
20	Flanged	15	11950	Aluminium	30	9600	63	189	±0.4	0.15	1.0	0.12
30		35	8700	Aluminium	114	17800	97	233	±0.5	0.20	1.5	0.24
38		65	7350	Aluminium	245	37400	108	318	±0.6	0.20	1.5	0.35
42		95	6820	Aluminium	396	54700	120	499	±0.6	0.20	1.5	0.49
45		170	5750	Aluminium	931	95800	132	738	±0.9	0.20	1.5	0.82
55 Al		340	4800	Aluminium	1665	144100	160	894	±1.1	0.25	1.5	1.50
55 ³⁾		340	4800	Steel	4996	144100	160	894	±1.0	0.25	1.5	3.20
65 ³⁾	600	3850	Steel	13318	322740	212	1365	±1.0	0.30	1.5	5.50	

¹⁾ For selection see page 22 et seqq.

²⁾ Figures refer to the complete coupling with max. bore.

³⁾ Hub made of steel welded with bellow.

Review of shaft-hub-connection: Friction torques T_R [Nm] for hub type 2.5

Size	Ø3	Ø4	Ø5	Ø6	Ø7	Ø8	Ø9	Ø10	Ø11	Ø12	Ø14	Ø15	Ø16	Ø18	Ø19	Ø20	Ø24	Ø25	Ø28	Ø30	Ø32	Ø35	Ø38	Ø40	Ø42	Ø45	Ø50	Ø55	Ø60	Ø65	
7	0.84	0.91	0.97	1.04	1.10																										
9	1.87	1.98	2.09	2.20	2.31	2.41	2.52																								
12		3.48	3.65	3.81	3.98	4.14	4.31	4.48	4.64	4.81																					
16			8.5	8.8	9.1	9.4	9.7	9.9	10.2	10.5	11.1	11.4	11.7																		
20						17.6	18.1	18.6	19.1	19.5	20.5	21.0	21.4	22.4	22.9	23.3															
30									33.1	33.8	35.1	35.8	36.5	37.8	38.5	39.2	41.9	42.5	44.6	45.9											
38											79.2	80.4	81.7	84.2	85.4	86.6	91.6	92.8	96.5	99.0	102	105	109								
42											84.2	85.4	86.6	89.1	90.3	91.6	96.5	97.8	102	104	106	110	114	116	119						
45																157	165	167	173	177	181	187	193	197	200	206					
55 Al																270	281	284	293	298	304	313	321	327	333	341	356	371			
55 ³⁾																	397	401	413	421	429	442	454	462	470	482	502	523			
65 ³⁾																					720	732	750	768	780	792	810	840	870	900	930

Ordering example:	TOOLFLEX® 30 S	2.5	Ø25	2.5	Ø30
	Size and type of coupling	Hub type	Finish bore	Hub type	Finish bore

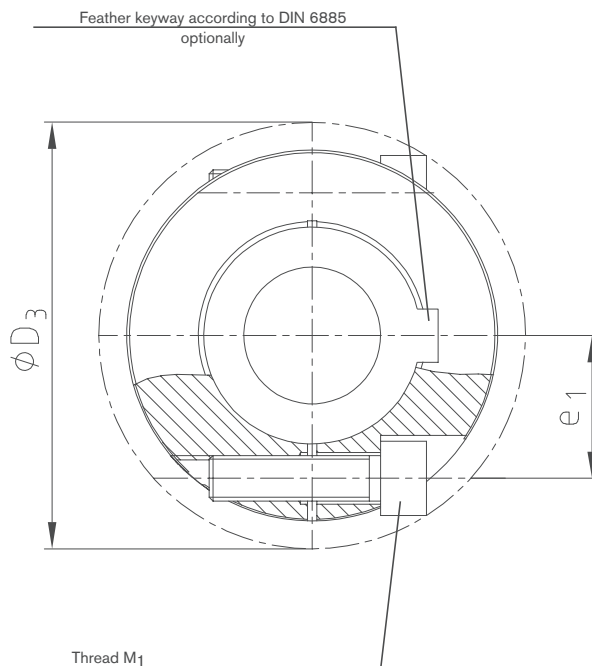
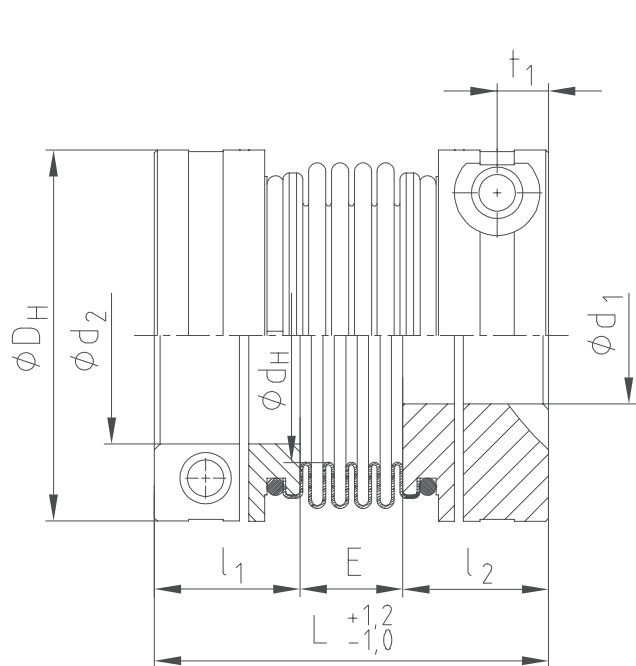

ROTEX® GS

Backlash-free
servo couplings

TOOLFLEX®

Other types:
Type for FANUC motors

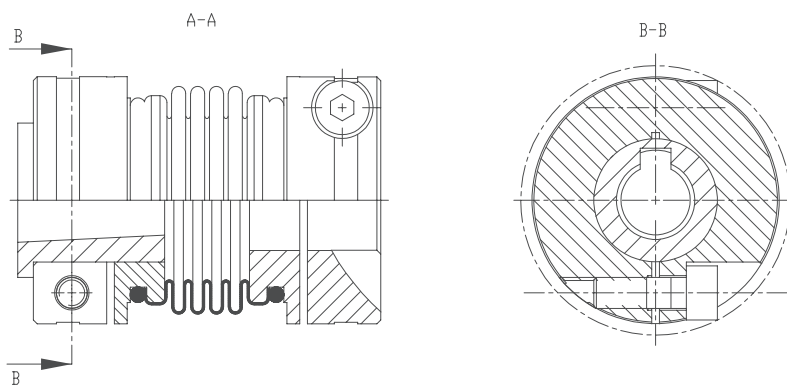

RADEX®-NC

Types of hubs

Type 2.5



Clamping hub double slot without feather keyway

Type 2.6



Clamping hub double slot with feather keyway

COUNTEX®

TOOLFLEX® M

Metal bellow-type couplings

Type M: with clamping hubs

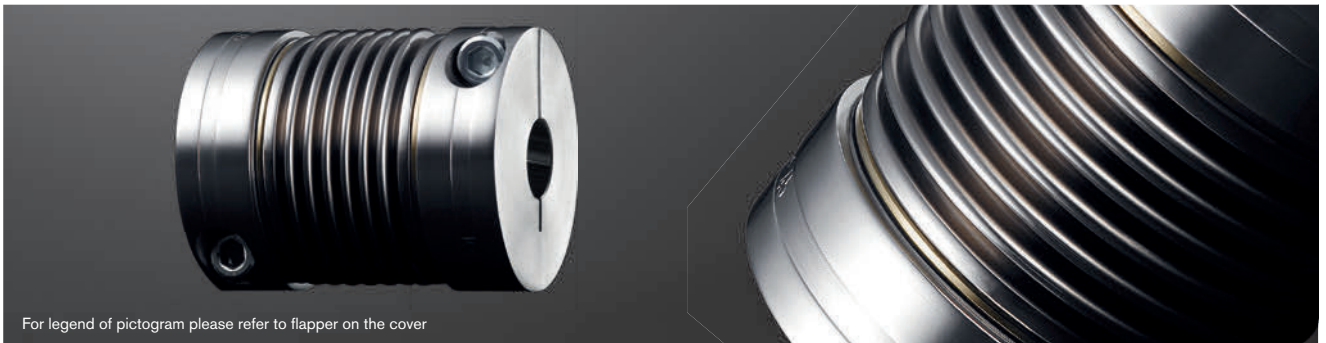

For legend of pictogram please refer to flapper on the cover

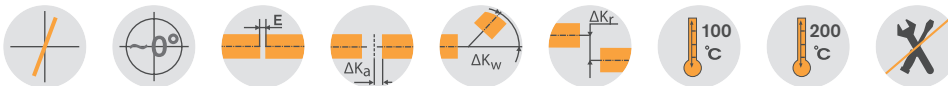

TOOLFLEX® Type M with clamping hubs - Hub material aluminium (size 55/65 steel)/bellow material stainless steel

Size	Dimensions [mm]											
	Finish bore d		General					Clamping screws DIN EN ISO 4762				
	Min.	Max.	L	l ₁ , l ₂	E	D _H	d _H	M ₁	DK	t ₁	e ₁	T _A [Nm]
7	3	7	26	9	8	15	9	M2	16.5	3.2	5	0.37
9	3	9	32	11	10	20	12	M2.5	21.5	3.5	7.1	0.76
12	4	12	38	13	12	25	16	M3	26.5	4	8.5	1.34
16	5	16	49	17.0	15	32	20	M4	35.0	5	12	2.9
20	8	20	62	21.5	19	40	27	M5	43.5	6	14.5	6
30	10	30	72	23.0	26	55	33	M6	58.0	7	19	10
38	12	38	81	25.5	30	65	42	M8	72.6	9	25	25
42	14	42	95	30.0	35	70	46	M8	76.1	9	27	25
45	14	45	103	32.0	39	83	58	M10	89.0	11	30	49
55 Al	20	55	125	40.0	45	100	73	M11	106.0	14	37	86
55 ³⁾	20	55	125	40.0	45	100	73	M12	106.0	14	37	120
65 ³⁾	30	65	142	45.0	52	125	95	M14	127.2	15	45	185

Technical data

Size	Bellow-hub-connection	Torque of bellow T _{KN} [Nm] ¹⁾	Max. speed [rpm]	Hub material	Moment of inertia ²⁾ [x10 ⁻⁶ kgm ²]	Torsion spring stiffness C _T [Nm/rad]	Axial stiffness C _a [N/mm]	Radial stiffness C _r [N/mm]	Perm. displacements			Weight ²⁾ [kg]
									Axial [mm]	Radial [mm]	Angular [degree]	
7	Bonded	1	31800	Aluminium	0.3	300	—	—	±0.4	0.15	1.0	0.008
9		1.5	23800	Aluminium	1.0	580	—	—	±0.5	0.20	1.5	0.015
12		2	19100	Aluminium	2.7	980	—	—	±0.6	0.20	1.5	0.03
16		5	14900	Aluminium	10	3050	29	92	±0.5	0.20	1.5	0.06
20	Flanged	15	11950	Aluminium	32	6600	42	126	±0.6	0.20	1.5	0.14
30		35	8700	Aluminium	123	14800	65	155	±0.8	0.25	2.0	0.31
38		65	7350	Aluminium	262	24900	72	212	±0.8	0.25	2.0	0.45
42		95	6820	Aluminium	427	36500	80	333	±0.8	0.25	2.0	0.52
45		170	5750	Aluminium	1020	64000	88	492	±1.0	0.25	2.0	1.13
55 Al	3)	340	4800	Aluminium	1706	96100	107	598	±1.1	0.30	2.0	2.0
55 ³⁾		340	4800	Steel	5118	96100	107	598	±1.0	0.30	2.0	3.3
65 ³⁾		600	3850	Steel	13727	226550	135	910	±2.0	0.35	2.0	5.6

¹⁾ For selection see page 22 et seqq.

²⁾ Figures refer to the complete coupling with max. bore.

³⁾ Hub made of steel welded with bellow.

Review of shaft-hub-connection: Friction torques T_R [Nm] for hub type 2.5

Size	Ø3	Ø4	Ø5	Ø6	Ø7	Ø8	Ø9	Ø10	Ø11	Ø12	Ø14	Ø15	Ø16	Ø18	Ø19	Ø20	Ø24	Ø25	Ø28	Ø30	Ø32	Ø35	Ø38	Ø40	Ø42	Ø45	Ø50	Ø55	Ø60	Ø65	
7	0.84	0.91	0.97	1.04	1.10																										
9	1.87	1.98	2.09	2.20	2.31	2.41	2.52																								
12		3.48	3.65	3.81	3.98	4.14	4.31	4.48	4.64	4.81																					
16			8.5	8.8	9.1	9.4	9.7	9.9	10.2	10.5	11.1	11.4	11.7																		
20						17.6	18.1	18.6	19.1	19.5	20.5	21.0	21.4	22.4	22.9	23.3															
30									33.1	33.8	35.1	35.8	36.5	37.8	38.5	39.2	41.9	42.5	44.6	45.9											
38										79.2	80.4	81.7	84.2	85.4	86.6	91.6	92.8	96.5	99.0	102	105	109									
42										84.2	85.4	86.6	89.1	90.3	91.6	96.5	97.8	102	104	106	110	114	116	119							
45															157	165	167	173	177	181	187	193	197	200	206						
55 Al																270	281	284	293	298	304	313	321	327	333	341	356	371			
55 ³⁾																	397	401	413	421	429	442	454	462	470	482	502	523			
65 ³⁾																					720	732	750	768	780	792	810	840	870	900	930

Ordering example:	TOOLFLEX® 30 M	2.5 - Ø25		2.5 - Ø30	
	Size and type of coupling	Hub type	Finish bore	Hub type	Finish bore

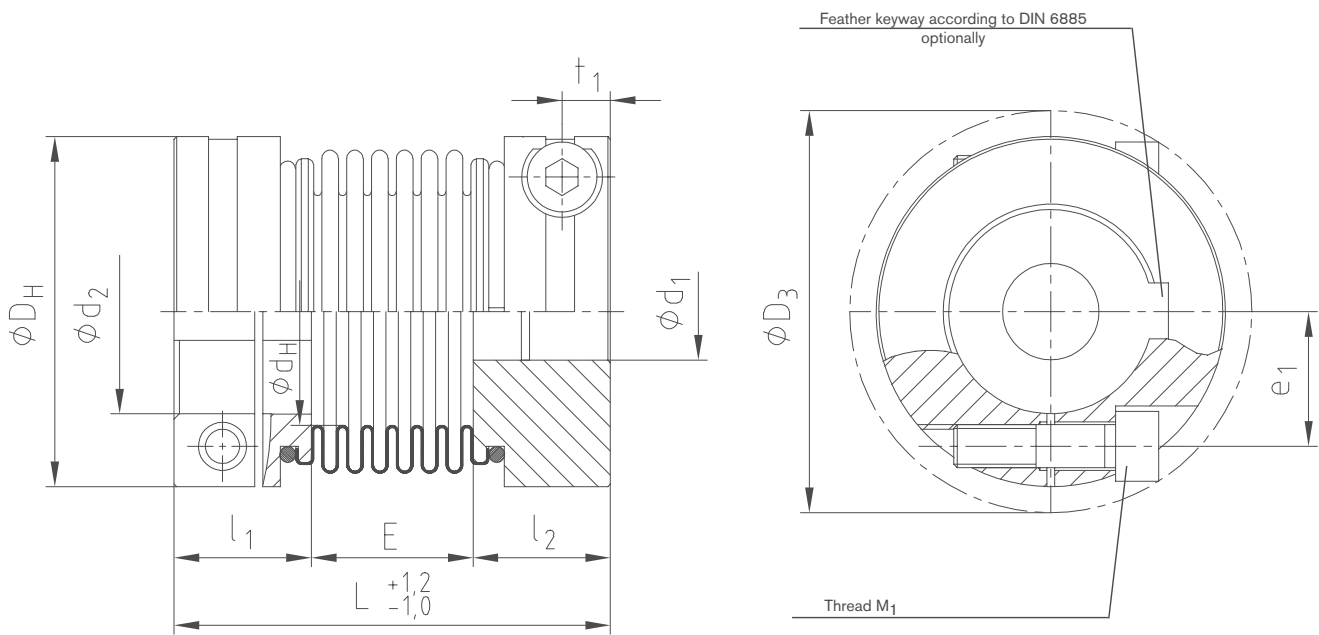

ROTEX® GS

TOOLFLEX®

Backlash-free servo couplings

Other types:
Type for FANUC motors

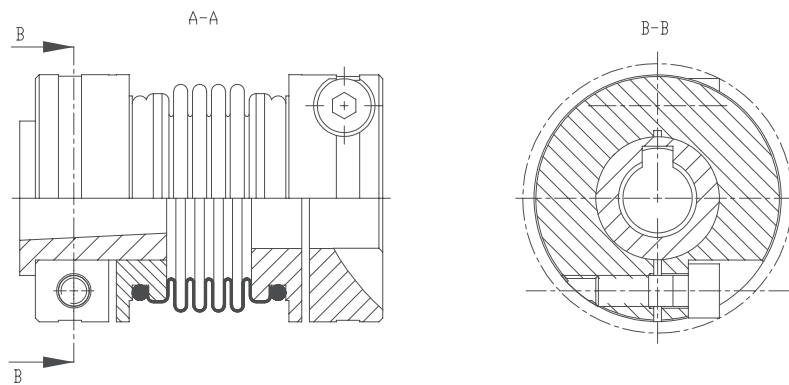

RADEX®-NC

Types of hubs

Type 2.5

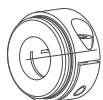

Clamping hub double slot without feather keyway

Type 2.6



Clamping hub double slot with feather keyway

COUNTLEX®

TOOLFLEX® KN

Metal bellow-type couplings

Taper hubs for high friction torques

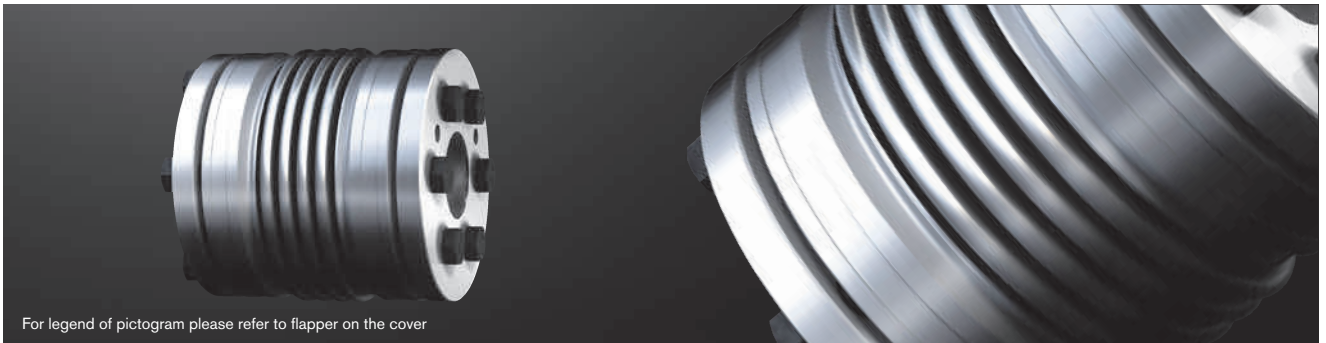

For legend of pictogram please refer to flapper on the cover

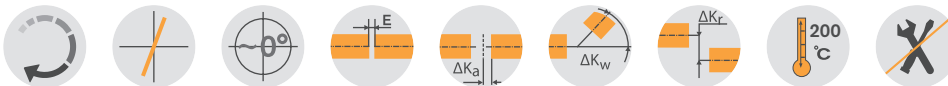

TOOLFLEX® Type S-KN - Hub material steel/bellow material stainless steel

Size	Torque of bellow $T_{KN}^{1)}$ [Nm]	Max. speed [rpm]	Dimensions [mm]													Weight ⁴⁾ [kg]	
			Finish bore d		L	L_{total}	l_1, l_2	D_H	D_1	D_2	Clamping screws DIN EN ISO 4017			Extraction thread			
			Min.	Max.							4 layers	4 layers	M	T_A [Nm]	z = number		M ₁
30	35	15280	12	22	48	54	22	50	43	47	M4	2.9	12	M4	6	1.2	0.4
38	65	12600	12	28	56	63	26	60.5	52	56	M5	6	12	M5	6	1.4	0.7
42	95	11580	14	35	64	71	29	66	60	63	M5	6	12	M5	6	1.4	0.8
45	170	9300	15	40	74.5	82.5	34	82	68	77	M6	14	12	M6	6	3	1.5
55 ²⁾	340	7870	15	56	95.5	106	40	97	95	95	M8	35	12	M8	6	6	2.5

TOOLFLEX® Type M-KN - Hub material steel/bellow material stainless steel

Size	Torque of bellow $T_{KN}^{1)}$ [Nm]	Max. speed [rpm]	Dimensions [mm]													Weight ⁴⁾ [kg]	
			Finish bore d		L	L_{total}	l_1, l_2	D_H	D_1	D_2	Clamping screws DIN EN ISO 4017			Extraction thread			
			Min.	Max.							6 layers	6 layers	M	T_A [Nm]	z = number		M ₁
30	35	15280	12	22	57	63	22	50	43	47	M4	2.9	12	M4	6	1.2	0.4
38	65	12600	12	28	68	75	26	60.5	52	56	M5	6	12	M5	6	1.4	0.7
42	95	11580	14	35	75	82	29	66	60	63	M5	6	12	M5	6	1.4	0.8
45	170	9300	15	40	91	99	34	82	68	77	M6	14	12	M6	6	3	1.5
55 ²⁾	340	7870	15	56	109	120	40	97	95	95	M8	35	12	M8	6	6	2.5

¹⁾ For selection see page 22 et seqq.

²⁾ Hub made of steel welded with bellow.

³⁾ After assembly of the clamping screws (M) tighten the extraction thread (M₁) at the tightening torque T_{A1} specified.

⁴⁾ Figures refer to the complete coupling with max. bore.

Review of shaft-hub-connection: Friction torques T_R [Nm] for hub type 6.5

Size	Ø14	Ø15	Ø16	Ø19	Ø20	Ø24	Ø25	Ø28	Ø30	Ø32	Ø35	Ø38	Ø40	Ø42	Ø45	Ø48	Ø50	Ø55
30	50	58	66	71	79													
38		81	92	130	103	149	161	202										
42				105	117	168	131	164	189	215	257							
45					230	332	230	288	331	376	451	531	589					
55 ⁴⁾							483	606	696	792	585	690	764	843	967	1101	1194	1445

Ordering example:

TOOLFLEX® 38 S-KN	6.5 - Ø15	6.5 - Ø22
Size and type of coupling	Finish bore	Finish bore

TOOLFLEX® S-KN

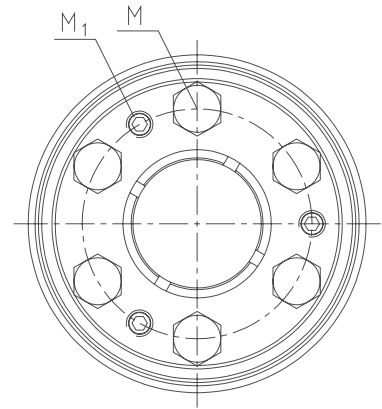
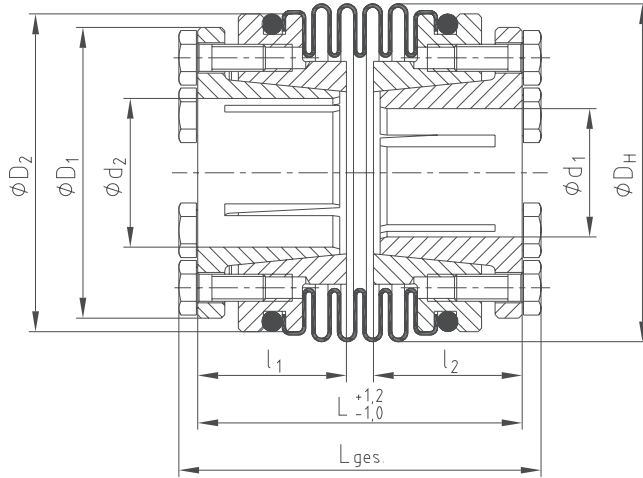

TOOLFLEX® M-KN

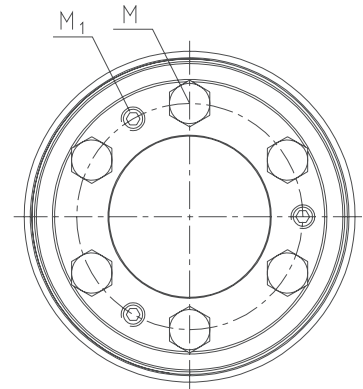
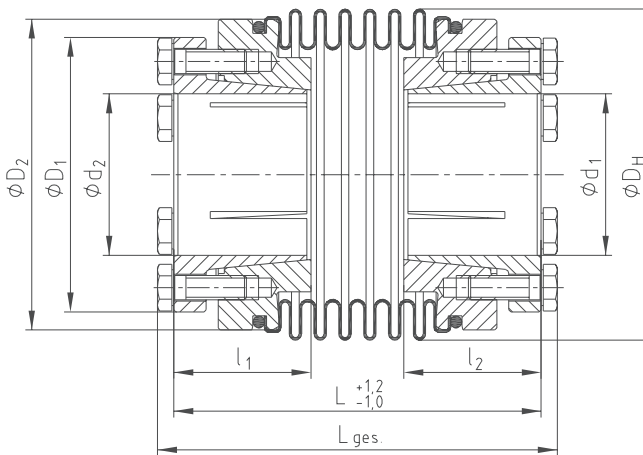

Other types:

TOOLFLEX® KN for FANUC motors

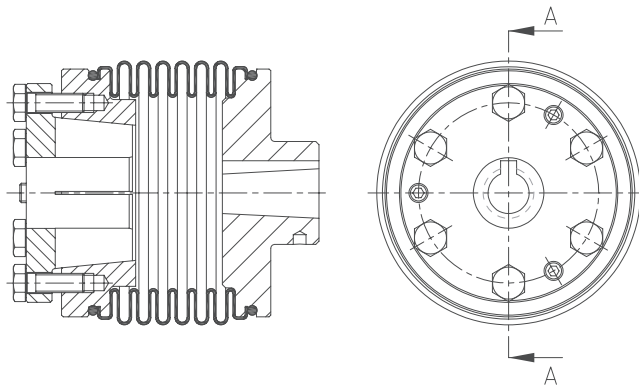

Types of hubs

Type 6.5

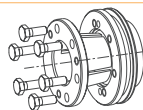

Taper hub KN

TOOLFLEX® PI

Metal bellow-type couplings

Axial plug-in



For legend of pictogram please refer to flapper on the cover

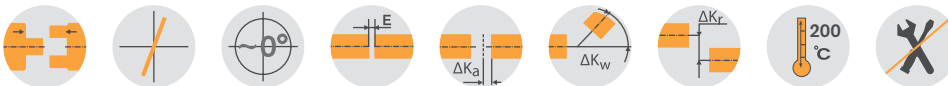

TOOLFLEX® Type S-PI - Hub material aluminium/bellow material stainless steel

Size	Type	Dimensions [mm]													
		General									Clamping screws DIN EN ISO 4762				
		Min. d ₁ , d ₂	Max. d ₁	Max. d ₂	L ¹⁾	l ₁	l ₂	E	D _H	H	M ₁ , M ₂	DK	e	t ₁ , t ₂	T _A [Nm]
20	S	8	20	20	67.0	21.5	33.5	12.0	40	0.5 - 1	M5	43.5	14.5	6	6
30	S	10	30	28	73.5	23.0	33.5	17.0	55	0.5 - 1	M6	58.0	19.0	7	10
38	S	12	38	32	87.5	25.5	44.0	18.0	65	0.5 - 1.5	M8	72.6	25.0	9	25
42	S	14	42	35	93.0	30	39.0	21.0	70	0.5 - 1.5	M8	76.1	25.0	9	25
45	S	14	45	42	96.0	32.0	41.5	22.5	83	0.5 - 1.5	M10	89.0	30.0	11	49
55 ⁴⁾	S	20	55	55	130.1	40	58.5	31.5	100	0.5 - 1.5	M12	106.0	37	14	120

Technical data of TOOLFLEX® S-PI

Size	Type	Torque of bellow T _{KN} ²⁾ [Nm]	Max. speed [rpm]	Moment of inertia ³⁾ [x10 ⁻⁶ kgm ²]	Torsion spring stiffness C _T [Nm/rad]	Axial stiffness C _a [N/mm]	Radial stiffness C _r [N/mm]	Perm. displacements		Weight ³⁾ [kg]
								Radial [mm]	Angular [degree]	
20	S	15	11950	37	6600	63	189	0.15	1.0	0.15
30	S	35	8700	140	11500	97	233	0.20	1.5	0.29
38	S	65	7350	329	21500	108	318	0.20	1.5	0.50
42	S	95	6820	396	31500	120	499	0.20	1.5	0.49
45	S	170	5750	1031	55000	132	738	0.25	1.5	0.93
55 ⁴⁾	S	340	4800	6150	144100	160	894	0.25	1.5	3.80

TOOLFLEX® Type M-PI - Hub material aluminium/bellow material stainless steel

Size	Type	Dimensions [mm]													
		General									Clamping screws DIN EN ISO 4762				
		Min. d ₁ , d ₂	Max. d ₁	Max. d ₂	L ¹⁾	l ₁	l ₂	E	D _H	H	M ₁ , M ₂	DK	e	t ₁ , t ₂	T _A [Nm]
20	M	8	20	20	74.0	21.5	33.5	19.0	40	0.5 - 1	M5	43.5	14.5	6	6
30	M	10	30	28	82.5	23.0	33.5	26.0	55	0.5 - 1	M6	58.0	19.0	7	10
38	M	12	38	32	99.5	25.5	44.0	30.0	65	0.5 - 1.5	M8	72.6	25.0	9	25
42	M	14	42	35	104.0	30	39.0	32.0	70	0.5 - 1.5	M8	76.1	25.0	9	25
45	M	14	45	42	112.5	32.0	41.5	39.0	83	0.5 - 1.5	M10	89.0	30.0	11	49
55	M	20	55	55	143.6	40	58.5	45	100	0.5 - 1.5	M12	106.0	37	14	120

Technical data of TOOLFLEX® M-PI

Size	Type	Torque of bellow T _{KN} ²⁾ [Nm]	Max. speed [rpm]	Moment of inertia ³⁾ [x10 ⁻⁶ kgm ²]	Torsion spring stiffness C _T [Nm/rad]	Axial stiffness C _a [N/mm]	Radial stiffness C _r [N/mm]	Perm. displacements		Weight ³⁾ [kg]
								Radial [mm]	Angular [degree]	
20	M	15	11950	38	4900	42	126	0.20	1.5	0.16
30	M	35	8700	145	10200	65	155	0.25	2.0	0.31
38	M	65	7350	346	15100	72	212	0.25	2.0	0.52
42	M	95	6820	427	22000	80	333	0.25	2.0	0.52
45	M	170	5750	1127	41000	88	492	0.30	2.0	1.00
55 ⁴⁾	M	340	4800	6270	96100	107	598	0.30	2.0	3.90

¹⁾ When plugged in

²⁾ For selection see page 22 et seqq.

³⁾ Figures refer to the complete coupling with max. bore.

⁴⁾ Hub made of steel welded with bellow.

Review of shaft-hub-connection: Friction torques T_R [Nm] for hub type 2.5 for Ød₁/Ød₂

Size	Ø8	Ø9	Ø10	Ø11	Ø12	Ø14	Ø15	Ø16	Ø18	Ø19	Ø20	Ø24	Ø25	Ø28	Ø30	Ø32	Ø35	Ø38	Ø40	Ø42
20	17.6	18.1	18.6																	
30				33.1	33.8	35.1	35.8	36.5	37.8	38.5	39.2	41.9	42.5	44.6	45.9					
38						79.2	80.4	81.7	84.2	85.4	86.6	91.6	92.8	96.5	99.0	102				
42						79.2	80.4	81.7	84.2	85.4	86.6	91.6	92.8	96.5	99.0	102	105			
45											157	165	167	173	177	181	187	193	197	200
55												397	401	413	421	429	442	454	462	470

Ordering
example:

TOOLFLEX® 30 S-PI	d ₁ - Ø22	d ₂ - Ø18
Size and type of coupling	Finish bore	Finish bore

TOOLFLEX® S-PI

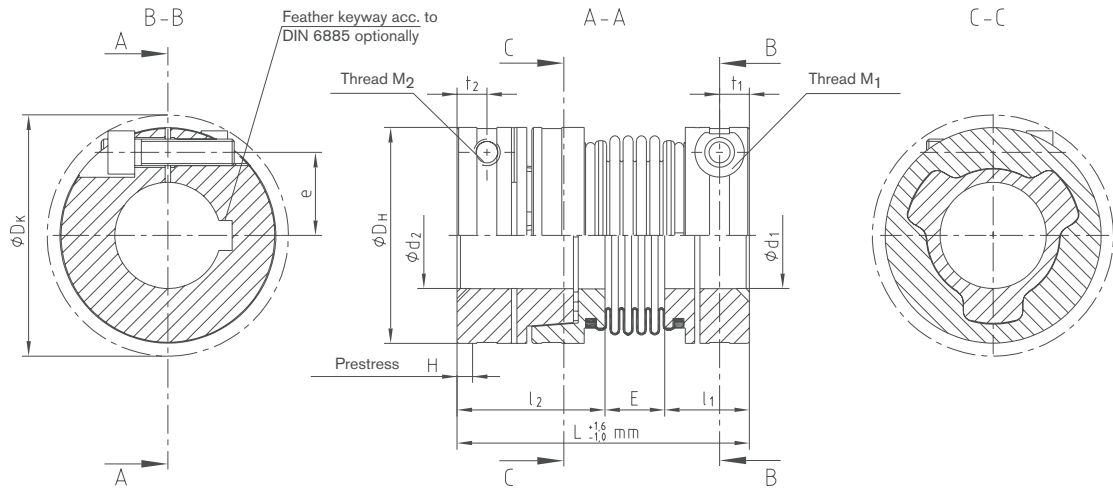

TOOLFLEX® M-PI

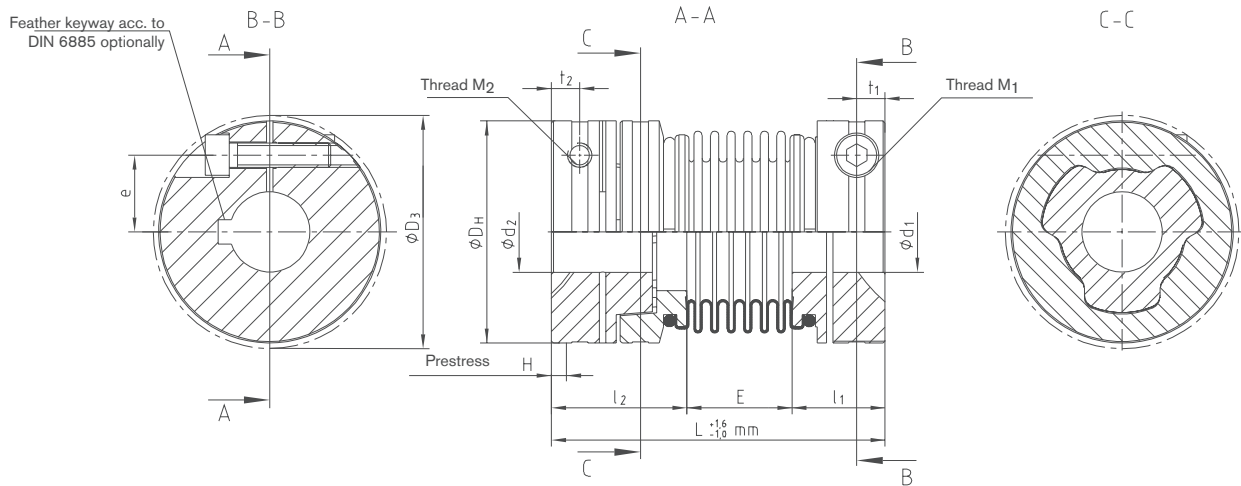

ROTEX® GS

TOOLFLEX®

RADEX®-NC

COUNTEX®

Backlash-free
servo couplings

TOOLFLEX® CF

Metal bellow-type couplings

Flange programme

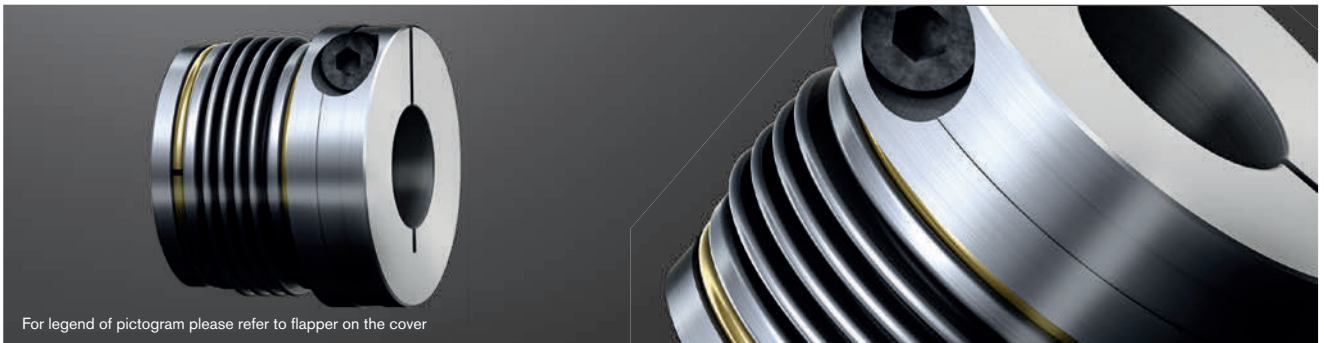

For legend of pictogram please refer to flapper on the cover



TOOLFLEX® Type S-CF - Hub material aluminium (size 55 steel)/bellow material stainless steel

Size	Finish bore d		Dimensions [mm]									Clamping screws DIN EN ISO 4762					Flange	
	Min.	Max.	D _H	D _B	D _F	d ₂ H7	l ₃	l ₁	l ₂	E	L	DK	e ₁	t ₁	M	T _A [Nm]	D _T	M ₁
30	10	30	55	50	47	25	1.5	16	23.0	10.5	49.5	58.0	19	7	M6	10	30	M4
						29											34	
38	12	38	65	60.5	55.75	29	1.5	18	25.5	11.0	54.5	72.6	25	9	M8	25	35	M5
						36											42	
42	14	42	70	66	62.95	36	1.5	21	30.0	15.0	66.0	76.1	27	9	M8	25	42	M5
						43											49	
45	14	45	83	82	77	38	1.5	23	32.0	14.5	69.5	89.0	30	11	M10	49	45	M6
						49											56	
55 ²⁾	20	55	100	97	95	51	1.5	28	40.0	23.5	91.5	106.0	37	14	M12	120	60	M8
						68											78	

Technical data

Size	Type	Torque of bellow T _{KN} ¹⁾ [Nm]	Max. speed [rpm]	Torsion spring stiff- ness C _T [Nm/rad]	Axial stiffness C _a [N/mm]	Radial stiffness C _r [N/mm]	Perm. displacements		
							Axial [mm]	Radial [mm]	Angular [degree]
30	S	35	8700	14800	97	233	±0.5	0.20	1.5
38	S	65	7350	24900	108	318	±0.6	0.20	1.5
42	S	95	6820	36500	120	499	±0.6	0.20	1.5
45	S	170	5750	64000	132	738	±0.9	0.25	1.5
55 ²⁾	S	340	4800	96100	160	894	±1.0	0.25	1.5

TOOLFLEX® Type M-CF - Hub material aluminium (size 55 steel)/bellow material stainless steel

Size	Finish bore		Dimensions [mm]									Clamping screws DIN EN ISO 4762					Flange	
	d ₁ min.	d ₁ max.	D _H	D _B	D _F	d ₂ H7	l ₃	l ₁	l ₂	E	L	DK	e ₁	t ₁	M	T _A [Nm]	D _T	M ₁
30	10	30	55	50	47	25	1.5	16	23.0	19.5	58.5	58.0	19	7	M6	10	30	M4
						29											34	
38	12	38	65	60.5	55.75	29	1.5	18	25.5	23.0	66.5	72.6	25	9	M8	25	35	M5
						36											42	
42	14	42	70	66	62.95	36	1.5	21	30.0	26.0	77.0	76.1	27	9	M8	25	42	M5
						43											49	
45	14	45	83	82	77	38	1.5	23	32.0	31.0	86.0	89.0	30	11	M10	49	45	M6
						49											56	
55 ²⁾	20	55	100	97	95	51	1.5	28	40.0	37.0	105.0	106.0	37	14	M12	120	60	M8
						68											78	

Technical data

Size	Type	Torque of bellow T _{KN} ¹⁾ [Nm]	Max. speed [rpm]	Torsion spring stiff- ness C _T [Nm/rad]	Axial stiffness C _a [N/mm]	Radial stiffness C _r [N/mm]	Perm. displacements		
							Axial [mm]	Radial [mm]	Angular [degree]
30	M	35	8700	14800	65	155	±0.8	0.25	2.0
38	M	65	7350	24900	72	212	±0.8	0.25	2.0
42	M	95	6820	36500	80	333	±0.8	0.25	2.0
45	M	170	5750	64000	88	492	±1.0	0.30	2.0
55 ²⁾	M	340	4800	96100	107	598	±1.0	0.30	2.0

¹⁾ For selection see page 22 et seqq.

²⁾ Hub made of steel welded with bellow.

Review of shaft-hub-connection: Friction torques T_R [Nm] for hub type 2.5

Size	Ø10	Ø11	Ø12	Ø13	Ø14	Ø15	Ø16	Ø18	Ø19	Ø20	Ø24	Ø25	Ø28	Ø30	Ø32	Ø35	Ø38	Ø40	Ø42	Ø45	Ø50	Ø55	
30			33.1	33.8	35.1	35.8	36.5	37.8	38.5	39.2	41.9	42.5	44.6	45.9									
38								84.2	85.4	86.6	91.6	92.8	96.5	99.0	102	105	109						
42					84.2	85.4	86.6	89.1	90.3	91.6	96.5	97.8	102	104	106	110	114	116	119				
45										157	165	167	173	177	181	187	193	197	200	206			
55 ⁴⁾											397	401	413	421	429	442	454	462	470	482	502	523	

Ordering
example:

TOOLFLEX® 38 M-CF	Ø15	Ø29 - Ø35 - 6xM5
Size and type of coupling	Finish bore	Dimensions flange (d ₂ - D _T - M ₁)

TOOLFLEX® S-CF

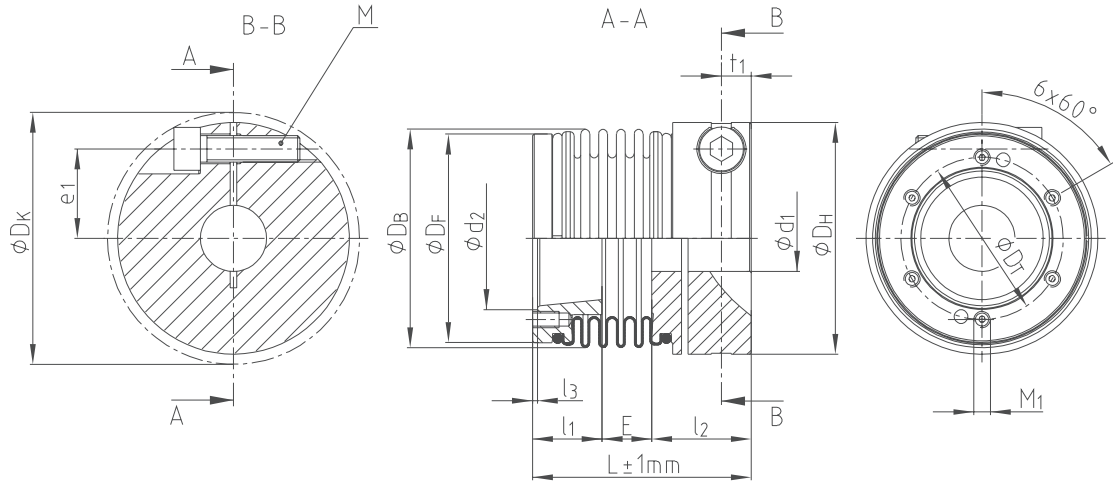

TOOLFLEX® M-CF

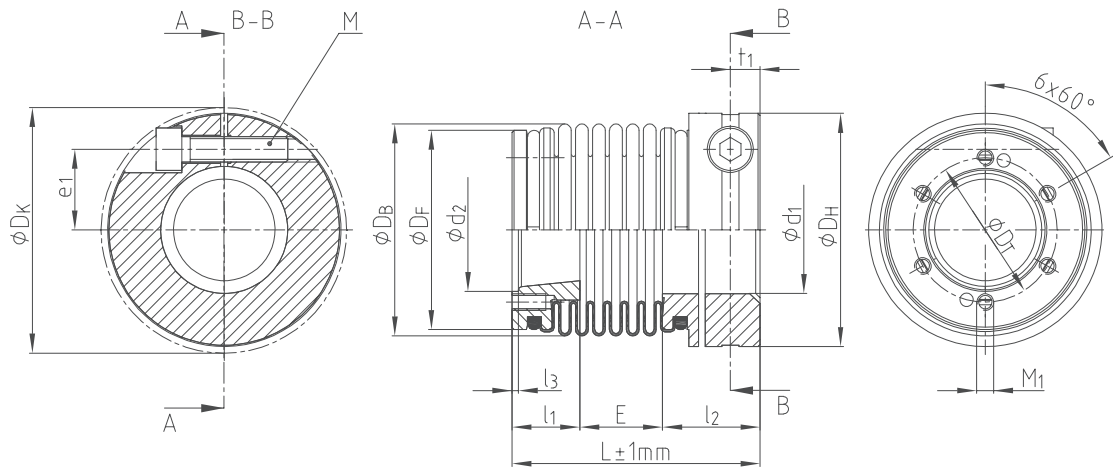

ROTEX® GS

TOOLFLEX®

RADEX®-NC

COUNTEX®

Backlash-free
servo couplings

TOOLFLEX® S-H / M-H

Metal bellow-type couplings

Shell clamping hubs

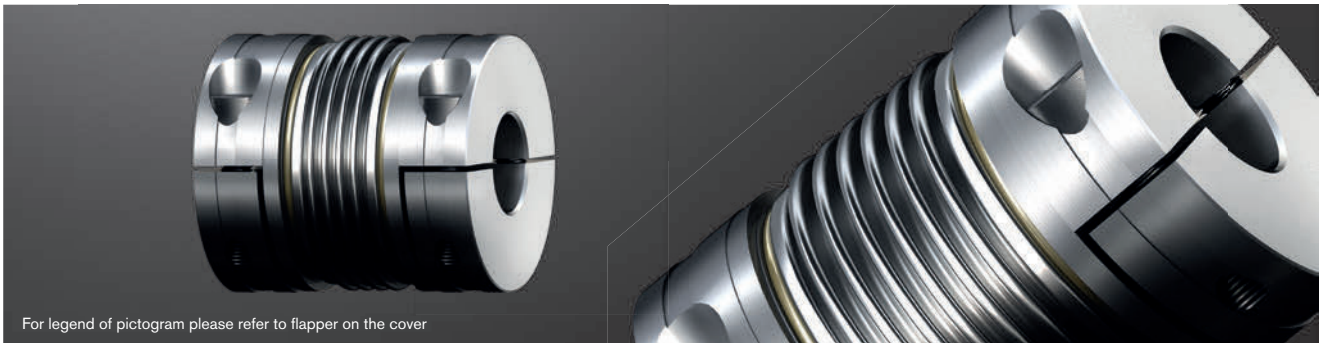

For legend of pictogram please refer to flapper on the cover

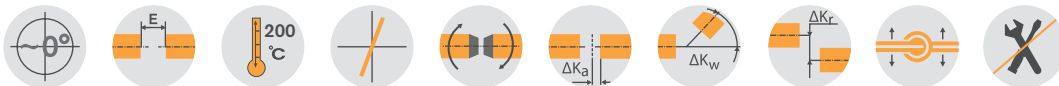

TOOLFLEX® type S-H / shell clamping hubs - Hub material aluminium/bellow material stainless steel

Size	Finish bore d		Dimensions [mm]												
	Min.	Max.	General								Clamping screws DIN EN ISO 4762				
			L	l _{1,2}	E	D _H	DK	E ₁	t ₁	x _{1,2}	e	M	T _A [Nm]		
20	8	20	51	19.5	12.0	40	41.2	26.0	5.5	12.5	14.5	M4	5.0		
30	10	28	68	25.5	17.0	55	57.7	34.0	7.5	17.0	19.0	M6	15.0		
38	12	38	78	30.0	18.0	65	72.6	36.0	9.5	21.0	25.0	M8	40.0		
45	14	45	94.5	36.0	22.5	83	88.8	46.5	11.0	24.0	30.0	M10	70.0		

Technical data of TOOLFLEX® S-H

Size	Bel- low-hub-con- nection	Torque of bellow T _{KN} ¹⁾ [Nm]	Max. speed [rpm]	Moment of inertia ²⁾ [x10 ⁻⁶ kgm ²]	Torsion spring stiffness C _T [Nm/rad]	Axial stiffness C _a [N/mm]	Radial stiffness C _r [N/mm]	Perm. displacements			Weight ²⁾ [kg]
								Axial [mm]	Radial [mm]	Angular [degree]	
20	Flanged	15	9550	28	9600	63	189	±0.4	0.15	1.0	0.110
30		35	6950	132	17800	97	233	±0.5	0.20	1.5	0.285
38		65	5850	292	37400	108	318	±0.6	0.20	1.5	0.422
45		170	4750	1003	95800	132	738	±0.9	0.20	1.5	0.897

TOOLFLEX® type M-H / shell clamping hubs - Hub material aluminium/bellow material stainless steel

Size	Finish bore d		Dimensions [mm]												
	Min.	Max.	General								Clamping screws DIN EN ISO 4762				
			L	l _{1,2}	E	D _H	DK	E ₁	t ₁	x _{1,2}	e	M	T _A [Nm]		
20	8	20	58	19.5	19.0	40	41.2	33.0	5.5	12.5	14.5	M4	5.0		
30	10	30	77	25.5	26.0	55	57.7	43.0	7.5	17.0	19.0	M6	15.0		
38	12	38	90	30.0	30.0	65	72.6	48.0	9.5	21.0	25.0	M8	40.0		
45	14	45	111	36.0	39.0	83	88.8	63.0	11.0	24.0	30.0	M10	70.0		

Technical data of TOOLFLEX® M-H

Size	Bel- low-hub-con- nection	Torque of bellow T _{KN} ¹⁾ [Nm]	Max. speed [rpm]	Moment of inertia ²⁾ [x10 ⁻⁶ kgm ²]	Torsion spring stiffness C _T [Nm/rad]	Axial stiffness C _a [N/mm]	Radial stiffness C _r [N/mm]	Perm. displacements			Weight ²⁾ [kg]
								Axial [mm]	Radial [mm]	Angular [degree]	
20	Flanged	15	9550	29	6600	42	126	±0.6	0.20	1.5	0.115
30		35	6950	138	14800	65	155	±0.8	0.25	2.0	0.304
38		65	5850	310	24900	72	212	±0.8	0.25	2.0	0.445
45		170	4750	1069	64000	88	492	±1.0	0.25	2.0	0.947

¹⁾ For selection see page 22 et seqq.

²⁾ Figures refer to the complete coupling with max. bore.

To make sure that the coupling can be assembled/disassembled radially, please observe the insertion dimension x_{1/2} of the shafts.

Review of shaft-hub-connection: Friction torques T_R [Nm] for hub type 2.5 for Ød₁/Ød₂

Size	Ø8	Ø9	Ø10	Ø11	Ø12	Ø14	Ø15	Ø16	Ø18	Ø19	Ø20	Ø24	Ø25	Ø28	Ø30	Ø32	Ø35	Ø38	Ø40	Ø42	Ø45	
20	12.5	14.1	15.7	17.2	18.8	21.9	23.5	25.1	28.2	29.8	31.3											
30			31.8	35.0	38.2	44.5	47.7	50.9	57.3	60.4	63.6	76.3	79.5	89.1								
38				74.9	87.4	93.7	99.9	112.4	118.6	124.9	149.9	156.1	174.8	187.3	199.8	218.5	237.3					
45					123.4	132.2	141.0	158.6	167.4	176.2	211.5	220.3	246.7	264.4	282.0	308.4	334.9	352.5	370.1	396.5		

Ordering
example:

TOOLFLEX® 30 S-H	7.8 - Ø25			7.9 - Ø30		
Size and type of coupling	Hub type	Finish bore	Hub type	Finish bore	Hub type	Finish bore

TOOLFLEX® S-H

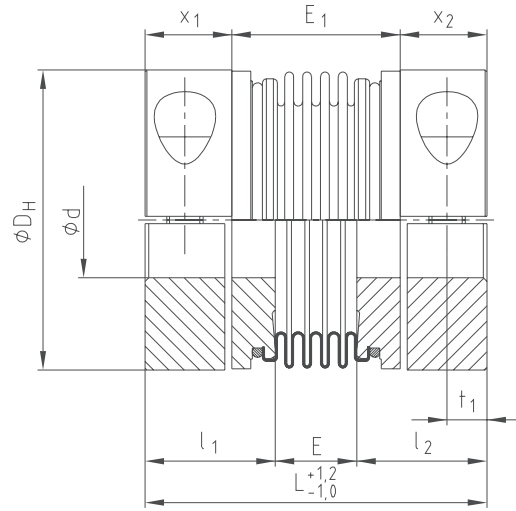
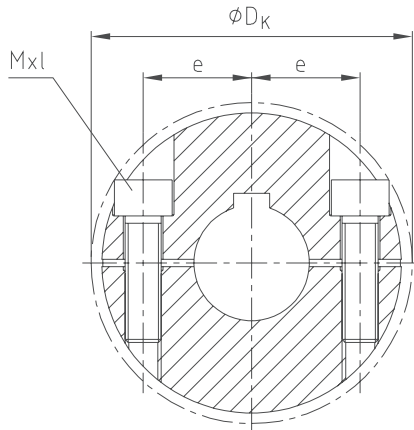

TOOLFLEX® M-H

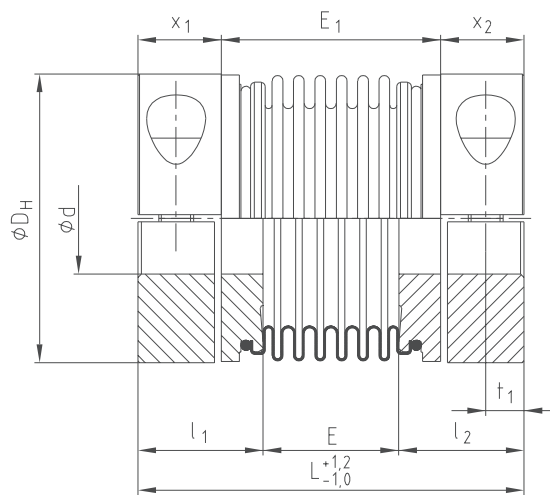
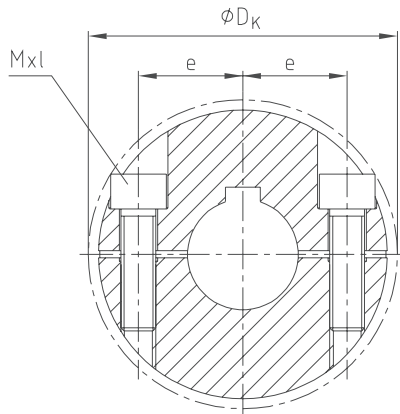

ROTEX® GS

TOOLFLEX®

RADEX®-NC

COUNTEX®

Backlash-free
servo couplings

Types of hubs

Type 7.8



clamping hub type H without feather keyway for single-cardanic connection

Type 7.9



clamping hub type H with feather keyway for single-cardanic connection (on request)

TOOLFLEX® ZR

Metal bellow-type couplings

Intermediate shaft coupling with aluminium pipe bonded

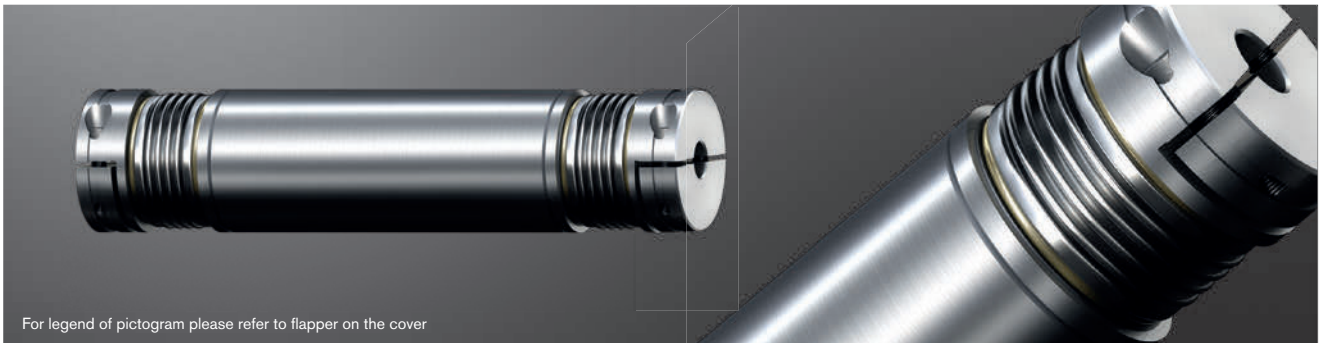

For legend of pictogram please refer to flapper on the cover

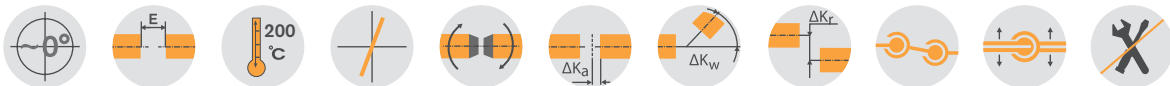

TOOLFLEX® type ZR / shell clamping hubs - Hub material aluminium/bellow material stainless steel

Size	Finish bore d		Dimensions [mm]											Clamping screws DIN EN ISO 4762			
	Min.	Max.	D _H	L	l ₃	General		LZR = LR + 2 • l ₃				dR	DK	t ₁	e	M	T _A [Nm]
						Min.	Max.	Min.	Max.	Min.	Max.						
20	8	20	40	40	12.5	80	2975	105	3000	40	41.2	5.5	14.5	M4	5		
30	10	28	55	58.5	17.0	114	3466	148	3500	50	58.0	7.5	19	M6	15		
38	12	38	65	61	21.0	129	3958	171	4000	60	72.6	9.5	25	M8	40		
45	14	45	83	78.5	25.0	149	3950	199	4000	80	89.0	11.0	30	M10	70		

Technical data of TOOLFLEX® ZR

Size	Torque of bellow T _{KN} ¹⁾ [Nm]	Moment of inertia [10 ⁻³ kgm ²]		Static torsion spring stiffness [Nm/rad]
		Z _R hub ²⁾	Pipe/meter	
20	15	0.024378	0.329	1935
30	35	0.121256	0.673	3800
38	65	0.253162	1.199	7240
45	170	0.961451	4.560	23183

¹⁾ For selection see page 22 et seqq.

²⁾ Figures refer to the complete coupling with max. bore.

³⁾ Torsion spring stiffness with a length of 1 m of intermediate pipe with L_{pipe} = LZR · 2 · L

For inquiries and orders please specify the shaft distance dimension L_R along with the maximum speed to review the critical bending speed.

Straightness/concentricity of pipes according to DIN EN 755-1.

Review of shaft-hub-connection: Friction torques T_R [Nm] for hub type 7.5 for Ød₁/Ød₂

Size	Ø8	Ø9	Ø10	Ø11	Ø12	Ø14	Ø15	Ø16	Ø18	Ø19	Ø20	Ø24	Ø25	Ø28	Ø30	Ø32	Ø35	Ø38	Ø40	Ø42	Ø45	
20	12.5	14.1	15.7	17.2	18.8	21.9	23.5	25.1	28.2	29.8	31.3											
30			31.8	35.0	38.2	44.5	47.7	50.9	57.3	60.4	63.6	76.3	79.5	89.1								
38					74.9	87.4	93.7	99.9	112.4	118.6	124.9	149.9	156.1	174.8	187.3	199.8	218.5	237.3				
45						123.4	132.2	141.0	158.6	167.4	176.2	211.5	220.3	246.7	264.4	282.0	308.4	334.9	352.5	370.1	396.5	

Ordering example:

TOOLFLEX® 30	ZR	1200 mm	7.5 - Ø24		7.6 - Ø24	
Size and type of coupling	Type	Shaft distance dimension (L _R)	Hub type	Finish bore	Hub type	Finish bore

TOOLFLEX® ZR

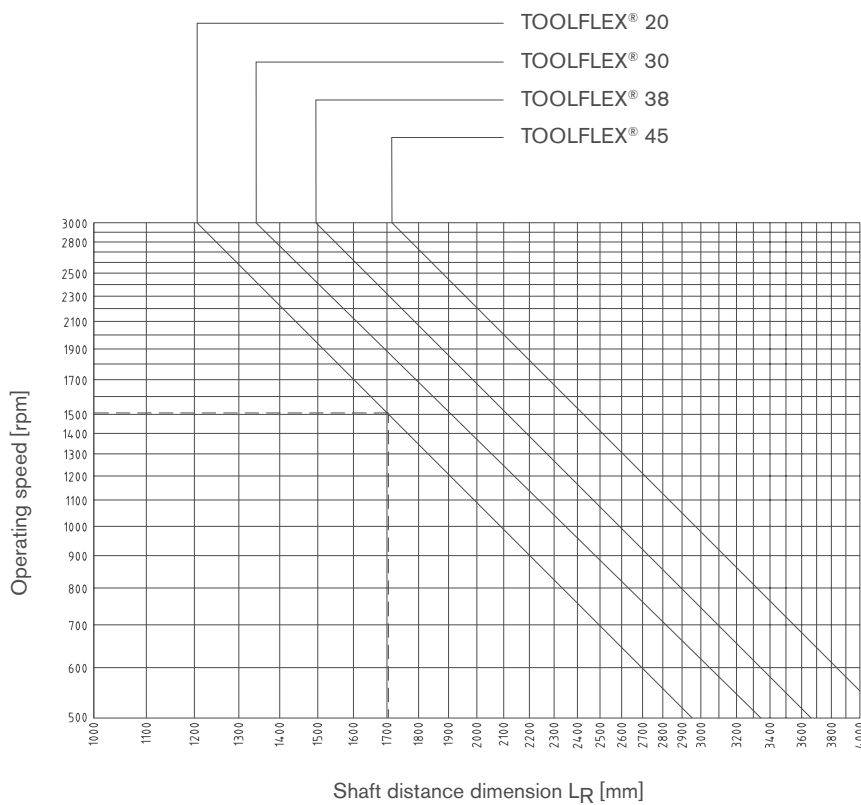
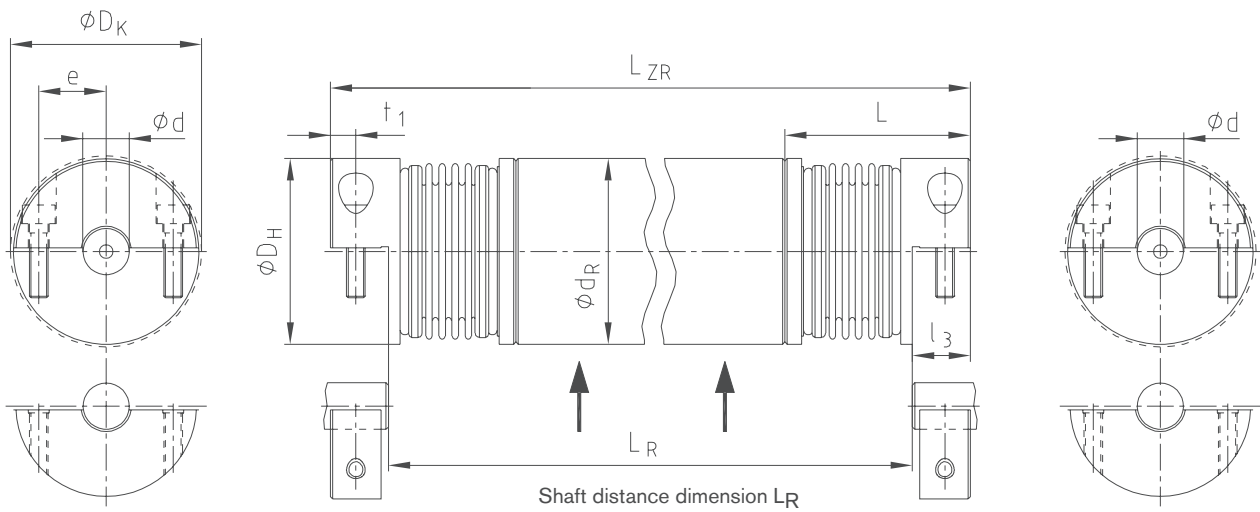

Types of hubs

Type 7.5



Clamping hub type DH without feather keyway for double-cardanic connection

Type 7.6



Clamping hub type DH with feather keyway for double-cardanic connection (on request)